



High-Performance and High-Capacity Centrifuges



TO MAKE HISTORY, YOU NEED HISTORY

Since the introduction of the first commercial ultracentrifuge in 1947 – the classic Beckman Model L – Beckman Coulter has been at the forefront of centrifuge innovation. Although the physics of this basic separation technique never change, Beckman Coulter continually designs new and innovative rotors and accessories, and develops advanced methods that allow the forces of centrifugation to be applied in new ways.

This centrifuge product selection guide is designed to help you determine the most efficient centrifuge tools for your laboratory.

Each section begins with a brief description of instruments that Beckman Coulter offers within that centrifuge category. Because biocontainment is a major concern in today's laboratories, Beckman Coulter provides a number of options that address this issue. Special biocontainment accessories are available across our centrifuge product line and are identified with this icon: 

Rotors with this symbol have been tested* to demonstrate containment of aerosols under normal operating conditions of the associated Beckman Coulter centrifuge when used and maintained as instructed.

Following the centrifuge descriptions, listings of their rotors are included with information on speed and g-force capability. Also included is information on tubes and bottles that can be used and the adapters they require.

Tubes and bottles are cross-referenced in a separate section that provides details on tube materials, chemical compatibility, tube designs, and tube closure options.

A reference section at the back of the guide includes quick-reference charts on instrument and tube selection and frequently-used formulas, as well as a listing of centrifuge literature and training tools available from Beckman Coulter.

* The rotors were tested for microbiological containment¹ at an independent, third-party testing facility² and found to be suitable for use with materials up to ACDP category.³ Improper use or maintenance may affect seal integrity and thus containment. Testing by these facilities does not imply their endorsement of these products.

1. Harper, G. J. (1984) Evaluation of sealed containers for use in centrifuges by a dynamic microbiological method. *J. Clin Pathol.* 37, 1134-1139.

2. CAMR, Porton Down, U.K., or USAMRIID, Fort Detrick, Maryland, U.S.A.

3. Advisory Committee on Dangerous Pathogens (1984). Categorization of pathogens according to hazard and categories of containment. HMSO, ISBN0 11 883761 3.

Contact your local Beckman Coulter office

Australia, Gladesville (61) 2 9844-6000 Canada, Mississauga (1) 905 819 1234 China, Beijing (86) 10 6515 6028
Czech Republic, Prague (420) 267 00 85 13 Eastern Europe, Middle East, North Africa, South West Asia: Switzerland, Nyon (41) 22 365 3707
France, Villepinte (33) 1 49 90 90 00 Germany, Krefeld (49) 2151 33 35 Hong Kong (852) 2814 7431 India, Mumbai (91) 22 3080 5101
Italy, Cassinadé Pecchi (Milan) (39) 02 953921 Japan, Tokyo (81) 3 5530 8500 Korea, Seoul (82) 2 404 2146 Latin America (1) (305) 380 4709
Mexico, Mexico City (001) 52 55 9183 2800 Netherlands, Mijdrecht (31) 297 230630 Puerto Rico (787) 747 3335 Singapore (65) 6339 3633
South Africa/Sub-Saharan Africa, Johannesburg (27) 11 805 2014/5 Spain, Madrid (34) 91 3836080 Sweden, Bromma (46) 8 564 85 900
Switzerland, Nyon (41) 0800 850 810 Taiwan, Taipei (886) 2 2378 3456 Turkey, Istanbul (90) 216 309 1900 UK, High Wycombe (44) 01494 441181
USA, Fullerton, CA (1) 800 742 2345

Additional centrifugation resources:

<http://www.beckmancoulter.com/centrifugefirst>

Table of Contents

High-Performance and High-Capacity Centrifugation

| | |
|---|------|
| Avanti® J-30I High-Performance Centrifuge | 1-2 |
| Avanti J-26 XP Series High-Performance Centrifuges | 1-3 |
| Avanti J-E Series High-Performance Centrifuge | 1-4 |
| Avanti J-HC Centrifuge | 1-5 |
| J6-MI High-Capacity Centrifuge | 1-6 |
| HarvestLine™ System Liners | 1-7 |
| SpinTrace™ II Laboratory Information Network System..... | 1-8 |
| High-Performance Centrifuge/Rotor Compatibility Chart | 1-9 |
| High-Capacity Centrifuge/Rotor Compatibility Chart..... | 1-11 |
| High-Performance and High-Capacity Rotor Summary..... | 1-12 |
| Fixed-Angle Rotors..... | 1-15 |
| Swinging-Bucket Rotors..... | 1-36 |
| Zonal and Reorienting Gradient Rotors | 1-67 |
| Elutriator Rotors..... | 1-68 |

Tubes and Bottles

| | |
|---|------|
| Tubes and Bottles for Every Application..... | 2-1 |
| Tube Selection Considerations | |
| Compatibility of Tube Material with Solvents and Samples | 2-2 |
| Gradient Formation and Fractionation..... | 2-2 |
| High-Temperature Centrifugation..... | 2-2 |
| Tube Sizes | 2-2 |
| Tube Cleaning, Sterilization, and Reuse | 2-2 |
| Tube Closures | 2-3 |
| A Quick-Reference Chart to Tube Materials and Their Properties | 2-3 |
| General Filling and Sealing Requirements | 2-4 |
| High-Performance and High-Capacity Bottles | 2-5 |
| Adapters for Non-Beckman Coulter Tubes/Bottles | 2-6 |
| Adapters and Sleeves for Glass Tubes in Beckman Coulter High-Performance Rotors | 2-6 |
| Tubes and Bottles (Listed by Volume)..... | 2-7 |
| Tools and Supplies | 2-10 |

Reference

| | |
|------------------------------------|-----|
| Guide to Centrifuge Selection..... | 3-2 |
| Useful Formulas..... | 3-4 |

Support Services

| | |
|---|-----|
| On-Call, On-Line, On-Site, and On-File Support..... | 3-6 |
|---|-----|

High-Performance and High-Capacity Centrifugation

1

| | | | |
|--|------|---|------|
| Avanti® J-30I High-Performance Centrifuge | 1-2 | Fixed-Angle Rotors | 1-15 |
| Avanti J-26 XP Series High-Performance Centrifuges | 1-3 | JA-30.50 Ti | 1-15 |
| Avanti J-E Series High-Performance Centrifuge | 1-4 | JA-25.50 | 1-16 |
| Avanti J-HC Centrifuge | 1-5 | JA-25.15 | 1-17 |
| J6-MI High-Capacity Centrifuge | 1-6 | JA-21 | 1-18 |
| HarvestLine™ System Liners | 1-7 | JA-20.1 | 1-19 |
| SpinTrace™ II Laboratory Information Network System..... | 1-8 | JA-20 | 1-20 |
| High-Performance Centrifuge/Rotor Compatibility Chart .. | 1-9 | JA-18.1 | 1-21 |
| High-Capacity Centrifuge/Rotor Compatibility Chart..... | 1-11 | JA-18 | 1-22 |
| High-Performance and High-Capacity Rotor Summary.... | 1-12 | JA-17 | 1-23 |
| | | J-Lite® JLA-16.250 | 1-24 |
| | | F14BCI-6x250y | 1-25 |
| | | F14BCI-14x50cy | 1-36 |
| | | JA-14 | 1-27 |
| | | JA-12 | 1-28 |
| | | J-Lite JLA-10.500 | 1-29 |
| | | F10BCI-6x500y | 1-30 |
| | | JA-10 | 1-31 |
| | | J-Lite JLA-9.1000 | 1-32 |
| | | J-Lite JLA-8.1000 | 1-34 |
| | | Swinging Bucket Rotors | 1-36 |
| | | JS-24.38 | 1-36 |
| | | JS-24.15 | 1-37 |
| | | JS-13.1 | 1-38 |
| | | JS-7.5 | 1-39 |
| | | JS-5.9 | 1-42 |
| | | JS-5.3 | 1-43 |
| | | JS-5.2 | 1-45 |
| | | JS-5.0 | 1-48 |
| | | JS-4.3 | 1-49 |
| | | JS-4.2 | 1-53 |
| | | JS-4.2A | 1-56 |
| | | JS-4.2SM | 1-59 |
| | | JS-4.2SMA | 1-60 |
| | | JS-4.0 | 1-61 |
| | | JS-3.0 | 1-64 |
| | | Zonal and Reorienting Gradient Rotors | 1-67 |
| | | JCF-Z | 1-67 |
| | | Elutriation Rotors | 1-69 |
| | | JE-5.0 | 1-69 |
| | | JE-6B | 1-71 |

High-Performance Centrifugation

1

Avanti® J-30I High-Performance Centrifuge

The Maximum g-force for High Performance

The Avanti J-30I High-Performance Centrifuge System gives you the fastest separations possible—in the shortest amount of time. Swinging bucket and fixed-angle rotors provide maximum separation forces in excess of 100 000 x g at speeds up to 30 000 rpm. Your productivity is ensured by unmatched accel/decel rates and an easy run set-up. Your sample spends more time at full force and less time in the centrifuge.



Avanti J-30I High-Performance Centrifuge

Specifications

| | |
|---------------------------------|---|
| Maximum Speed | 30 000 rpm |
| Maximum <i>g</i> -force | 110 500 × <i>g</i> |
| Speed Control | ± 10 rpm of set speed or 0.15%, whichever is greater |
| Imbalance Tolerance | ± 2.5% opposing sample imbalance |
| Drive Type | Microprocessor-controlled Switched Reluctance Drive* |
| Centrifuge Warranty | 1 year |
| Drive Warranty | 3 years |
| Drive Cooling | Air-cooled |
| Refrigeration System | Non-CFC, non-ozone depleting refrigerant |
| Max. Capacity Volume | 4 000 mL |
| Single Tube Sample Volume Range | 1.5 – 1 000 mL |
| Set Temperature Range | -20° to 40°C in 1° increments |
| Temperature Control | ± 2°C of set |
| User-Settable Programs | 30 two-step programs |
| Time Setting | 1 min. to 99:59 hours, hold or ω ² t |
| Acceleration/Deceleration Rates | 12 accel/13 decel |
| Friction Reduction System | Yes |
| Zonal Capability | Yes |
| Dynamic Rotor Inertia Check | Automatic |
| Heat Output | 2.0 kW (6900 BTU/hr) |
| Sound Level | < 57 dBa (3 ft. from instrument at 30 000 rpm) |
| Dimensions | 71 cm x 86 cm x 86 cm (27.9 in. H × 33.9 in. D × 33.9 in. W) |
| Weight | 310 kg (680 lb) |
| Voltage Requirements | 208 V, 30 A, 60 Hz; 220 V, 30 A, 50 Hz; 220/380 V, 16 A, 50 Hz |

Part Numbers

| | 200/208/240 V 60 Hz | 230 V 50 Hz | 220/380 V 50 Hz, 3-Phase |
|--|---------------------------|----------------|-----------------------------|
| Avanti J-30I | 363118 | 63120 | 363121 |
| | 200/208/240 V 50/60 Hz | 230 V 50 Hz | 220/380 V 50 Hz, 3-Phase |
|  BioSafe Avanti J30I | A20691 | A20692 | A20693 |

* Manufactured under license from Switched Reluctance Drives Limited, Harrogate, UK.

High-Performance Centrifugation

Avanti® J-26 XP Series High-Performance Centrifuges

Highest Throughput Available—6 liters in under 10 minutes

The Avanti J-26 XP Series is designed for high throughput and versatility. Teamed with the J-LITE® JLA-8.1000 6-liter rotor, the J-LITE polycarbonate and polypropylene bottles, and disposable HarvestLine™ System liners, the J-26 XP centrifuges can process 6 liters in less time than it takes conventional centrifuges to process 3 liters. These are versatile high-performance systems as well, capable of running the full line of Beckman Coulter high-performance rotors—including the AllSpin™ (JS-5.3) rotor with optional microplate carriers and adapters for conical tubes and bottles.

Specifications



| | |
|---------------------------------|---|
| Maximum Speed | 26 000 rpm |
| Maximum <i>g</i> -force | 82 000 × <i>g</i> |
| Speed Control | ± 10 rpm of set speed or 0.1%, whichever is greater |
| Drive Type | Switched Reluctance Drive* |
| Drive Cooling | Air-cooled |
| Centrifuge Warranty | 1 year |
| Drive Warranty | 3 years |
| Refrigeration System | Non-CFC, non-ozone-depleting refrigerant |
| Max. Capacity Volume | 6 000 mL |
| Single Tube Sample Volume Range | 1.5 – 1 000 mL |
| Ambient Temperature Range | 16° to 38°C |
| Set Temperature Range | -10° to 40°C |
| Temperature Control | ± 2°C of set |
| User-Settable Programs | J-26 XPI: 30 two-step programs J-26 XP: No programming |
| Zonal Capability | J-26 XPI: Yes J-26 XP: No |
| Time Setting | 1 min. to 99:59 hours, hold or ω^2 (J-26 XPI) 1 min. to 3 hours, hold (J-26 XP) |
| Acceleration/Deceleration Rates | 12 accel/13 decel (J-26 XPI) 2 accel/3 decel (J-26 XP) |
| Dynamic Rotor Inertia Check | Automatic |
| Heat Output | 2.0 kW (6 900 BTU/hr) |
| Sound Level | < 57 dBA (3 ft. from instrument at maximum speed) |
| Dimensions | 865 mm × 876 mm × 711 mm (34.1 in. H × 34.5 in. D × 28 in. W) |
| Weight | 290 kg (640 lb) |

* Manufactured under license from Switched Reluctance Drives Limited, Harrogate, UK.



Avanti J-26 XP Series centrifuge

Part Numbers

| | 200/208/240 V 50/60 Hz | 230 V 50 Hz | 220/380 V 50 Hz, 3-Phase |
|--|---------------------------|----------------|-----------------------------|
| Avanti J-26 XPI | 393127 | 393128 | 393129 |
| Avanti J-26 XP | 393124 | 393125 | 393126 |
| Avanti J-26 XPI with Elutriation | 393133 | 393134 | 393135 |
| Avanti J-26 XP with Elutriation | 393130 | 393131 | 393132 |
| | 200/208/240 V 50/60 Hz | 230 V 50 Hz | 220/380 V 50 Hz, 3-Phase |
|  BioSafe Avanti J-26 XPI | A25574 | A25575 | A25576 |
|  BioSafe Avanti J-26 XP | A25577 | A25578 | A25579 |

High-Performance Centrifugation

1

Avanti® J-E High-Performance Centrifuge

Compact High Performance Centrifuge that fits directly in your lab

Whether your application is related to cellular, genetic, or protein analysis, the Avanti J-E with speeds up to 21 000 rpm (53 300 x g) coupled with powerful SR* drive technology provides you with fast separations.

A comprehensive line of labware, with up to twenty-four 96-well microtiter plate processing, 4 x 1L bottles, and HarvestLine™ System liners extend the versatility of this centrifuge. For clinical research applications, conical tubes and bottles for swinging bucket rotors spin volumes of 15, 50, 250, and 500 mL for effective blood component isolation with a variety of gradient kits.

The J-E is energy efficient for low heat output plus the quiet operation ensures a comfortable, productive work environment.



Avanti J-E High-Performance Centrifuge

Specifications

| | |
|---------------------------------|---|
| Maximum Speed | 21 000 rpm |
| Maximum g-force | 53 300 x g |
| Speed Control | Actual rotor speed, ± 50 rpm of set speed |
| Drive Type | Switched Reluctance Drive* |
| Drive Cooling | Air-cooled |
| Centrifuge Warranty | 1 year |
| Drive Warranty | 2 years |
| Refrigeration System | Non-CFC, non-ozone-depleting refrigerant |
| Max. Capacity Volume | 4 000 mL |
| Ambient Temperature Range | 15° to 35°C |
| Set Temperature Range | -10° to 40°C in 1° increments |
| Temperature Control | ± 2°C of set |
| Time Setting | 1 min. to 99:59 hours, hold |
| Acceleration/Deceleration Rates | 2 accel/3 decel |
| Heat Output | 2.0 kW (6 900 BTU/hr) |
| Sound Level | < 65 dBa (3 ft. from instrument at maximum speed) |
| Dimensions | 91.4 cm x 80 cm x 63.5 cm (60 in. H x 31.5 in. D x 25 in. W) |
| Weight | 267.4 kg (589 lb) |

* Manufactured under license from Switched Reluctance Drives Limited, Harrogate, UK.

Part Numbers

| | 208/240 V 50 Hz | 230 V 50/60 Hz | 200 V 50/60 Hz |
|--|---------------------------|-------------------|-----------------------|
| Avanti J-E | 369001 | 369003 | 369005 |
| | 200/208/240 V 50/60 Hz | 230 V 50/60 Hz | 220/380 V 50/60 Hz |
|  BioSafe Avanti JE | 969352 | A20698 | A20699 |

High-Capacity Centrifugation

Avanti® J-HC Centrifuge

A New Dimension in Bioprocessing

The Avanti J-HC High Capacity Centrifuge provides you with a complete solution for batch bioprocessing. A maximum of 9 liters can be spun at speeds of 5 000 rpm and $7\,480 \times g$ for greater sample throughput. This allows processing of up to 36 liters per hour when harvesting bacteria. Enhanced operator safety is provided with disposable HarvestLine™ system liners.



Avanti J-HC High-Capacity Bioprocessing Centrifuge System

Specifications

| | |
|----------------------------------|---|
| Maximum Speed | 10 000 rpm |
| Maximum <i>g</i> -force | 17 100 × <i>g</i> (JA-10 rotor @ 10 000 rpm) |
| Speed Control | ± 10 rpm of set speed |
| Max. Capacity | 9 000 mL |
| Single Bucket Volume | 2 250 mL |
| Set Temperature Range | -10° to 40°C |
| Temperature Control | ± 2°C |
| User-Settable Programs | 30 two-step programs |
| Friction Reduction | Automatic |
| Maximum Heat Dissipation to Room | 2.0 kW (6 900 BTU/hr) |
| Noise Level | 60 dBA (3 ft. from instrument at 10 000 rpm) |
| Weight | 300 kg (660 lb) |
| Dimensions | 91 cm × 86 cm × 71 cm (36 in. H × 34 in. D × 28 in. W) |

Part Numbers

| | 200/208/240 V 50/60 Hz | 230 V 50 Hz | 380 V 50 Hz, 3-Phase |
|--|---------------------------|----------------|-------------------------|
| Avanti J-HC | 367501 | 367502 | 367503 |
| Total CGMP Bioprocessing Centrifuge System | | 367521 | 367522 |
| Bioprocessing Centrifuge System | 368484 | 368485 | 368486 |

High-Capacity Centrifugation

J6-MI High-Capacity Centrifuge Unmatched Versatility for Multiple-Application Requirements

The J6-MI continues the Beckman Coulter tradition of rugged reliability in a quiet floor centrifuge. The J6, with six-liter capacity, offers a wide range of innovative rotors, carriers, adapters, and other accessories to handle all your high-capacity centrifuge applications. (The J6-MI centrifuge can also run most Avanti J Series Rotors to 6 000 rpm.)

The J6-MI instrument generates speeds and forces to 6 000 rpm and 6 835 x g.

Color-Coded Multi-Disc™ Adapters for All Popular Tubes and Bottles

Beckman Coulter's Multi-Disc Adapters bring real convenience to handling large numbers of samples. The first color-coded, stackable adapter discs for large capacity centrifugation, these modular adapter discs can be stacked to support various tube lengths and are easily disassembled for cleaning. A thick rubber bottom pad cushions tubes to protect from breakage. Specific adapters required for use with various tube sizes are included in the following rotor listings.

Aeroseal™ Covers

Aeroseal Covers are designed to provide added protection from hazardous aerosols. They fit the round buckets of J6 Swinging-Bucket Rotors with an O-ring seal. These clear covers let you see a broken tube so proper precautions can be taken before opening.



For more information on the J6-MI centrifuge, order DS-10035.



J6-MI centrifuge

| Part Numbers | 208 V | 240 V | 220 V |
|--|--------|--------|--------|
| | 60 Hz | 50 Hz | 50 Hz |
| J6-MI High-Capacity Centrifuge with Microprocessor Control and Brushless Induction Drive | 360291 | 360292 | 360293 |

High-Performance/High-Capacity Centrifugation

1

HarvestLine™ System Liners

Unique design enhances productivity

HarvestLine™ disposable bottle liners provide a significant improvement in the centrifugation of biological material. HarvestLine System liners save time and enhance operator safety by reducing exposure to endotoxins and other pathogenic material resulting from manual scraping of harvested solids from labware. Used in Avanti Series centrifuges, these unique liners provide a convenient method of loading, recovering, and storing samples.

HarvestLine liners can be sterilized (gamma radiation), placed in a freezer (-70°C) for prolonged storage, and are compatible with commonly used chemicals and solvents. They facilitate the harvesting of:

- Mammalian and insect culture separations
- Bacterial, yeast, and tissue homogenate isolations
- Virus harvesting for vaccine production—viral vector gene therapy and monoclonal antibody production.

JLA-8.1000 and JLA-9.1000 Fixed Angle Rotor with Liners

The 6 x 1 liter JLA-8.1000 composite rotor system with liners is ideal for harvesting bacterial and yeast cell cultures from fermenters, clearing cell debris from homogenates, or purifying large-volume viruses and polysaccharides for vaccine production. The 4 x 1 liter JLA-9.1000 rotor provides up to 16 800 x g for high throughput.

JS-5.0 Swinging Bucket Rotor with Liners

The 4 x 2.25 liter JS-5.0 rotor with liners is ideal for greater sample throughput. This system is ideal for separating bacterial, yeast, and tissue homogenates. At 7 480 x g, the rotor harvests *E. coli* at a clearing rate of 99% in less than 10 minutes (throughput of better than 36 liters per hour).



HarvestLine System for JLA-8.1000 and JLA-9.000 Rotors



HarvestLine System for JS-5.0 Rotor

Specifications

| | |
|---------------------------|-----------------------------------|
| Maximum Speed | |
| in the JS-5.0 rotor | 5 000 rpm |
| in the JLA-8.1000 rotor | 8 000 rpm |
| in the JLA-9.1000 rotor | 9 000 rpm |
| Maximum <i>g</i> -force | |
| in the JS-5.0 rotor | 7 480 × <i>g</i> |
| in the JLA-8.1000 rotor | 15 970 × <i>g</i> |
| in the JLA-9.1000 rotor | 16 800 × <i>g</i> |
| Run Time | Up to 20 min. instrument set time |
| Temperature Range | 4° to 10°C |
| Acceleration/Deceleration | Up to instrument maximum settings |

Part Numbers

| | |
|--------|---|
| 369264 | HarvestLine System Liner Kit Includes 369256 one-liter bottle liners (qty 120), 368740 filling rack, 977472 funnel, and 369267 instructional CD. |
| 369256 | HarvestLine System Liners Fits JLA-8.1000 or JLA-9.1000 one-liter bottles (qty. 120). |
| 368735 | HarvestLine System Liners Fits JS-5.0 J-Wide Cups (qty. 50)." |

High-Performance/High-Capacity Centrifugation

SpinTrace™ II Laboratory Information Network System New process documentation for CGMP compliance in bioprocessing



SpinTrace II is a laboratory information network for the Avanti® J-HC and J-26 XPI Series centrifuges developed to automatically and accurately collect data to enhance throughput and help meet CGMP compliance for the bioprocessing laboratory.

SpinTrace II is user friendly, providing consistent process control, complete traceability, information management, and centralized monitoring. The system includes an IBM-compatible personal computer that can simultaneously operate up to 32 Avanti J-HC and J-26 XPI Series centrifuges, each equipped with an optional bar code scanner.











Part Numbers

| | |
|--------|--|
| 367515 | SpinTrace II Network System & Computer (for connecting up to 8 centrifuges) |
| 975843 | SpinTrace II Computer Upgrade Card (to connect 8 to 24 centrifuges) |
| 975844 | SpinTrace II Computer Upgrade Card (to connect 24 to 32 centrifuges) |
| 367516 | SpinTrace II Interface Hardware (with a bar code scanner) |
| 367517 | SpinTrace II Interface Hardware (without a bar code scanner) |

High-Performance Centrifugation

1



High-Performance Centrifuge/Rotor Compatibility Chart

| | Avanti J-30I | Avanti J-26 XP | Avanti J-25 | Avanti J-E | J2 Series (except J2-HC) | Angle | Containment |
|---------------------------|--------------------------|-------------------------|----------------------------------|-------------------------|----------------------------------|-------|---|
| | Max. RPM/ g Force | Max. RPM/ g Force | Obsolete Max. RPM/ g Force | Max. RPM/ g Force | Obsolete Max. RPM/ g Force | | |
| Fixed-Angle Rotors | | | | | | | |
| JA-30.50 Ti | 30 000 <i>108 860</i> | 26 000 <i>81 800</i> | 25 000 <i>75 600</i> | N/A | 21 000 <i>53 300</i> | 34° | Single- or dual-locking lid/ fluid annulus |
| JA-25.50 | 25 000 <i>75 600</i> | 25 000 <i>75 600</i> | 25 000 <i>75 600</i> | 21 000 <i>53 300</i> | 21 000 <i>53 300</i> | 34° | Single- or dual-locking lid/ fluid annulus  |
| JA-25.15 | 25 000 <i>74 200</i> | 25 000 <i>74 200</i> | 25 000 <i>74 200</i> | N/A | 21 000 <i>52 400</i> | 25° | Single- or dual-locking lid/ fluid annulus  |
| JA-21 | 21 000 <i>50 400</i> | 21 000 <i>50 400</i> | 21 000 <i>50 400</i> | 21 000 <i>50 400</i> | 21 000 <i>50 400</i> | 40° | |
| JA-20.1 | 20 000 <i>51 500</i> | 20 000 <i>51 500</i> | 20 000 <i>51 500</i> | 20 000 <i>51 500</i> | 20 000 <i>51 500</i> | 23° |  |
| JA-20 | 20 000 <i>48 400</i> | 20 000 <i>48 400</i> | 20 000 <i>48 400</i> | 20 000 <i>48 400</i> | 20 000 <i>48 400</i> | 34° |  |
| JA-18.1 | 18 000 <i>42 100</i> | 18 000 <i>42 100</i> | 18 000 <i>42 100</i> | N/A | 18 000 <i>42 100</i> | 25° | N/A |
| JA-18 | 18 000 <i>47 900</i> | 18 000 <i>47 900</i> | 18 000 <i>47 900</i> | 16 000 <i>37 800</i> | 18 000 <i>47 900</i> | 23° | N/A  |
| JA-17 | 17 000 <i>39 800</i> | 17 000 <i>39 800</i> | 17 000 <i>39 800</i> | 17 000 <i>39 800</i> | 17 000 <i>39 800</i> | 25° |  |
| JLA-16.250 | 16 000 <i>38 400</i> | 16 000 <i>38 400</i> | 16 000 <i>38 400</i> | 16 000 <i>38 400</i> | 14 000 <i>29 400</i> | 25° | Single- or dual-locking lid/ fluid annulus  |
| F14BCI-14x50cy | 14 000 <i>33 500</i> | 14 000 <i>33 500</i> | 14 000 <i>33 500</i> | N/A | N/A | 34° | |
| JA-14 | 14 000 <i>30 100</i> | 14 000 <i>30 100</i> | 14 000 <i>30 100</i> | 14 000 <i>30 100</i> | 14 000 <i>30 100</i> | 25° |  |
| F14BCI-6x250y | 14 000 <i>30 000</i> | 14 000 <i>30 000</i> | 14 000 <i>30 000</i> | N/A | N/A | 23° | |
| JA-12 | 12 000 <i>23 200</i> | 12 000 <i>23 200</i> | 12 000 <i>23 200</i> | 12 000 <i>23 200</i> | 12 000 <i>23 200</i> | 35° | Single- or dual-locking lid/ fluid annulus  |
| JLA-10.500 | 10 000 <i>18 500</i> | 10 000 <i>18 500</i> | 10 000 <i>18 500</i> | 10 000 <i>18 500</i> | 10 000 <i>18 500</i> | 20° | Sealing Cannister covers  |
| JA-10 | 10 000 <i>17 700</i> | 10 000 <i>17 700</i> | 10 000 <i>17 700</i> | 10 000 <i>17 700</i> | N/A | 25° |  |
| F14BCI-6x500y | 10 000 <i>17 700</i> | 10 000 <i>17 700</i> | 10 000 <i>17 700</i> | N/A | N/A | 23° | |
| JLA-9.1000 | 9 000 <i>16 800</i> | 9 000 <i>16 800</i> | 9 000 <i>16 800</i> | 6 300 <i>8 300</i> | N/A | 20° | Integrated bottle seal |
| JLA-8.1000 | N/A | 8 000 <i>15 970</i> | N/A | N/A | N/A | 20° | Integrated bottle seal |

High-Performance Centrifugation

1

High-Performance Centrifuge/Rotor Compatibility Chart (*continued*)







| | Avanti J-30I | Avanti J-26 XP | Avanti J-25 | Avanti J-E | J2 Series (except J2-HC) | Angle | Containment |
|-------------------------------|--------------------------|-------------------------|----------------------------------|-------------------------|----------------------------------|-------|--|
| | Max. RPM/ g Force | Max. RPM/ g Force | Obsolete Max. RPM/ g Force | Max. RPM/ g Force | Obsolete Max. RPM/ g Force | | |
| Swinging Bucket Rotors | | | | | | | |
| JS-24.38 | 24 000 <i>103 900</i> | 10 000 <i>18 000</i> | 10 000 <i>18 000</i> | N/A | N/A | Horz. | Cap, O-ring |
| JS-24.15 | 24 000 <i>110 500</i> | 10 000 <i>19 190</i> | 10 000 <i>19 190</i> | N/A | N/A | Horz. | Cap, O-ring |
| JS-13.1 | 13 000 <i>26 500</i> | 13 000 <i>26 500</i> | 13 000 <i>26 500</i> | 13 000 <i>26 500</i> | 13 000 <i>26 500</i> | Horz. | |
| JS-7.5 | 7 500 <i>10 400</i> | 7 500 <i>10 400</i> | 7 500 <i>10 400</i> | N/A | 7 500 <i>10 400</i> | Horz. | N/A |
| JS-5.9 | 5 900 <i>6 870</i> | 5 900 <i>6 870</i> | 5 900 <i>6 870</i> | N/A | N/A | Horz. | N/A |
| JS-5.3 | N/A | 5 300 <i>6 130</i> | N/A | 5 300 <i>6 130</i> | N/A | Horz. | N/A |
| JS-4.3 | N/A | 4 300 <i>4 220</i> | N/A | N/A | N/A | Horz. | Aerosolve® Cannister  |
| JS-4.0 | N/A | 4 000 <i>4 050</i> | N/A | N/A | N/A | Horz. | Aeroseal™ Cover  |

| | Avanti J-30I | Avanti J-26 XP | Avanti J-25 | Avanti J-E | J2 Series (except J2-HC) |
|---|-------------------------|-------------------------|-------------------------|----------------------|-----------------------------|
| | Max. RPM/ g Force | Max. RPM/ g Force | Max. RPM/ g Force | Max. RPM/ g Force | Max. RPM/ g Force |
| Elutriation, Continuous Flow, and Zonal Rotors | | | | | |
| JE-5.0 | 5 000 | 5 000 <i>2 410</i> | 5 000 <i>2 410</i> | N/A | N/A |
| JE-6B | 6 000 <i>5 080</i> | N/A | 6 000 <i>5 080</i> | N/A | 6 000 <i>5 080</i> |
| JCF-Z Std. Core | 20 000 <i>39 900</i> | 20 000 <i>39 900</i> | 20 000 <i>39 900</i> | N/A | 20 000 <i>39 900</i> |
| JCF-Z Large Core | 20 000 <i>39 900</i> | 20 000 <i>39 900</i> | 20 000 <i>39 900</i> | N/A | 20 000 <i>39 900</i> |
| JCF-Z Small Core | 20 000 <i>39 900</i> | 20 000 <i>36 300</i> | 20 000 <i>39 900</i> | N/A | 20 000 <i>39 900</i> |
| JCF-Z Reograd Core | 20 000 <i>39 900</i> | 20 000 <i>39 900</i> | 20 000 <i>39 900</i> | N/A | 20 000 <i>39 900</i> |
| JCF-Z Zonal Core | 20 000 <i>39 900</i> | 20 000 <i>39 900</i> | 20 000 <i>39 900</i> | N/A | 20 000 <i>39 900</i> |

High-Capacity Centrifugation

1

High-Capacity Centrifuge/Rotor Compatibility Chart

| | Places x Largest Volume (ml) | Avanti J-HC Max. RPM/ g Force | J6-MI Max. RPM/ g Force | Angle | Containment | |
|-------------------------------|------------------------------------|-------------------------------------|-------------------------------|-------|-----------------|---|
| Fixed Angle Rotors | | | | | | |
| JLA-8.1000 | 6 x 1000 | 8 000 15 970 | N/A | 20° | Integrated seal |  |
| JA-10 | 6 x 500 | 10 000 17 700 | 6 000 6 370 | 25° | N/A | |
| Swinging Bucket Rotors | | | | | | |
| JS-5.2 | 4 x 1000 12 | N/A | 5 200 6 840 | Horz. | Aeroseal™ Cover |  |
| JS-5.0 | 4 x 2200 | 5 000 7 480 | N/A | Horz. | | |
| JS-4.2 | 6 x 1000 18 | 4 200 5 020 | 4 200 5 020 | Horz. | Aeroseal Cover |  |
| JS-4.2A | 6 x 1000 18 | 4 200 5 020 | 4 200 5 020 | Horz. | Aeroseal Cover |  |
| JS-4.2SM | 6 x 1000 18 | N/A | 4 200 4 900 | Horz. | | |
| JS-4.2SMA | 6 x 1000 | N/A | 4 200 4 900 | Horz. | | |
| JS-4.0 | 4 x 1000 | N/A | 4 000 4 050 | Horz. | Aeroseal Cover |  |
| JS-3.0 | 6 x 1000 | N/A | 3 000 2 560 | Horz. | Aeroseal Cover |  |

High-Performance/High-Capacity Centrifugation

1

High-Performance and High-Capacity Rotor Summary

| Rotor Type | Part Number | Maximum Speed (rpm) | Maximum Force at r_{min} (g) | Maximum Force at r_{max} (g) | k Factor | Number Tubes/Bottles and Size (diameter x length) mm/in. | Rotor Capacity (mL) | Approx. Accel. Time ¹ (min:sec) | Comments |
|---------------------------|-----------------------------------|---------------------|--------------------------------|--------------------------------|------------------|--|---------------------|--|---|
| Fixed-Angle Rotors | | | | | | | | | |
| JA-30.50 Ti | 363420 Biosafety Lid | 30 000 | 40 320 | 108 860 | 280 | 8 x 50 mL 29 x 104 mm (1.125 x 4 in.) | 400 mL | 5:15 ^a | Harvesting bacteria, processing tissue culture, subcellular particulates, routine pelleting such as precipitates and phase separation. |
| | 363421 Single Lock Lid | | | | | | | | |
| JA-25.50 | 363058 Biosafety Lid | 25 000 | 26 950 | 75 600 | 418 | 8 x 50 mL 29 x 105 mm (1.125 x 4 in.) | 400 mL | 3:30 ^b | High-force, efficient pelleting of cell particles from tissue homogenates. Short column virus purification. |
| | 363055 Single Lock Lid | | | | | | | | |
| JA-25.15 | 363050 Biosafety Lid | 25 000 | 36 400/ 22 400 | 74 200/ 60 200 | 265/ 380 | 24 x 15 mL 18 x 100 mm (0.625 x 4 in.) | 360 mL | 3:15 ^b | High-force, efficient pelleting of subcellular particles, bacteria, algae, and chloroplasts. Short column banding of virus and subcellular particles. |
| | 363054 Single Lock Lid | | | | | | | | |
| JA-21 | 334845 | 21 000 | 22 200 | 50 400 | 470 | 18 x 10 mL 16 x 80 mm (0.625 x 3 in.) | 180 mL | 1:30 ^b | High-force, fast, efficient separation of many samples in small volume. Viruses, bacteriophage, mitochondria, nuclei. |
| JA-20.1 | 342095 | 20 000 | 28 700 21 100 | 51 500 43 900 | 371/ 465 | 32 x 15 mL 18 x 99 mm (0.625 x 4 in.) | 480 mL | 1:30 ^b | High-force, large volume. Has 2 concentric rows of 15-mL tubes. Efficient separation of particles with 100 S or larger sedimentation coefficients. |
| JA-20 | 334831 | 20 000 | 14 300 | 48 400 | 770 | 8 x 50 mL 29 x 104 mm (1.125 x 4 in.) | 400 mL | 1:30 ^b | Harvesting bacteria and cell membranes, processing tissue homogenates, separating cell particulates. |
| JA-18.1 | 347824 | 18 000 | 34 500 | 42 100 | 156 ^c | 24 x 1.8 mL 11 x 38 mm (0.4 x 1.5 in.) | 43.2 mL | 1:20 ^b | High-force sedimentation in microcentrifuge-sized tubes under refrigerated conditions. Tube oriented at either a 25° or 45° angle. |
| JA-18 | 369679 | 18 000 | 23 200 | 47 900 | 566 | 10 x 100 mL 38 x 102 mm (1.5 x 4 in.) | 1 liter | 6:30 ^b | High-force, large volume. Pelleting bacteria, cell membranes, and subcellular organelles. |
| JA-17 | 369691 | 17 000 | 18 180 | 39 800 | 690 | 14 x 50 mL 29 x 104 mm (1.125 x 4 in.) | 700 mL | 2:30 ^b | Harvesting bacteria and cell membranes, processing tissue homogenates, separating cell particulates. |
| JLA-16.250 | 363930 Biosafety Lid | 16 000 | 13 200 | 39 300 | 1 350 | 6 x 250 mL 62 x 120 mm (2.5 x 5.5 in.) | 1.5 liters | 3:30 ^b | Harvesting bacteria and cell membranes, processing tissue homogenates, separating cell particulates. |
| | 363934 with Single Lock Lid | | | | | | | | |
| JA-14 | 339247 | 14 000 | 7 680 | 30 100 | 1 764 | 6 x 250 mL 62 x 120 mm (2.5 x 4.8 in.) | 1.5 liters | 4:00 ^b | General-purpose, large-volume, and multi-tube processing. |
| JA-12 | 360992 Biosafety Lid | 12 000 | 11 500 | 23 200 | 1 244 | 12 x 50 mL 30 x 103 mm conical (1.17 x 4 in.) | 600 mL | 3:30 ^b | General pelleting of cells, bacteria, and food products. Separating of proteins, viruses, and subcellular fractions. Phase separations and binding studies. |
| | 360993 with Single-locking Lid | | | | | | | | |

¹ Accel times are approximate, and subject to change.

^a Typical accel time in Avanti J-30I.

^b Typical accel time in Avanti J-25 Series.

^c At a 45° angle.

High-Performance/High-Capacity Centrifugation

1

High-Performance and High-Capacity Rotor Summary (continued)

| Rotor Type | Part Number | Maximum Speed (rpm) | Maximum Force at r_{min} (g) | Maximum Force at r_{max} (g) | k Factor | Number Tubes/Bottles and Size (diameter x length) | Rotor Capacity (mL) | Approx. Accel. Time ¹ (min:sec) | Comments |
|---------------------------------------|----------------------|---------------------|--------------------------------|--------------------------------|----------|---|---------------------|--|--|
| Fixed-Angle Rotors (continued) | | | | | | | | | |
| JLA-10.500 | 369681 with Closures | 10 000 | 6 050 | 18 500 | 2 840 | 6 x 500 mL 69 x 160 mm (2.75 x 6.5 in.) | 3 liters | 2:30 ^a | Lightweight, high-volume, fixed-angle rotor for initial processing of tissue homogenate and other large particles. |
| JA-10 | 334833 | 10 000 | 4 260 | 17 700 | 3 610 | 6 x 500 mL 69 x 160 mm (2.75 x 6.5 in.) | 3 liters | 4:30 ^a | High-volume, fixed-angle rotor for initial processing of tissue homogenate and other large particles. |
| JLA-9.1000 | 366754 | 9 000 | 7 440 | 16 800 | 2 540 | 4 x 1000 mL 95 x 191 mm (3.8 x 7.65 in.) | 4 liters | 2:30 ^b | General purpose, large-volume processing, pelleting of bacteria cell organelles, viruses, and precipitates. |
| JLA-8.1000 | 363688 | 8 000 | 8 530 | 15 970 | 2 482 | 6 x 1000 mL 95 x 191 mm (3.8 x 7.65 in.) | 6 liters | 6:00 ^b | General purpose, large-volume processing, pelleting of bacteria subcellular organelles, viruses and precipitates. |
| Swinging-Bucket Rotors | | | | | | | | | |
| JS-24.38 | 360743 | 24 000 | 48 600 | 103 900 | 334 | 6 x 38.5 mL 25 x 89 mm (1 x 3.5 in.) | 231 mL | 5:15 ^c | Harvesting bacteria, processing tissue homogenates, subcellular particulates, routine pelleting such as precipitates and phase separations. |
| JS-24.15 | 362396 | 24 000 | 50 900 | 110 500 | 376 | 6 x 15 mL 16 x 96 mm (0.625 x 3.75 in.) | 90 mL | 5:15 ^c | Harvesting bacteria, processing tissue homogenates, subcellular particulates, routine pelleting such as precipitates and phase separations. |
| JS-13.1 | 346963 | 13 000 | 7 760 | 26 500 | 1 841 | 6 x 50 mL 29 x 105 mm (1.125 x 4 in.) | 300 mL | 2:30 ^a | Density gradient centrifugation of cells. Sedimentation of nuclei and protein or nuclei acid precipitates. Clarification of tissue homogenates. |
| JS-7.5 | 336380 | 7 500 | 3 210 | 10 400 | 5 287 | 4 x 250 mL 62 x 136 mm (2.5 x 5.5 in.) | 1 L | 1:00 ^a | Initial processing of cells and removal of cell debris from culture media. Accepts round-bottom bottles for easier handling of pellets. |
| JS-5.9 | 369331 | 5 400 | 5 980 | 6 570 | | 10 microplates | | 1:00 ^a | High-throughput processing (DNA or RNA kits), serial dilution of small volumes. |
| JS-5.3 (AllSpin™) | 368690 | 5 300 | 5 170 | 6 870 | | 4 x 500 mL conical 24 microplates | 2 L | 2:00 ^d | Sucrose/glycerol gradients, centrifugal filtration, binding studies, clearing debris/large particles, pelleting, plasma protein precipitates. |
| JS-4.3 | 362734 | 4 300 | 1 532 | 4 220 | 13 892 | 4 x 750 mL 96 x 130 mm (3.8 x 5.2 in.) | 3 L | 1:00 ^b | Rapid sedimentation of protein precipitates, large particles, cells, binding studies, and separating serum from whole blood. |
| JS-4.0 | 339086 | 4 000 | 1 540 | 4 050 | 15 300 | 4 x 1000 97 x 167 (3.82 x 6.57 in.) | 4 L | 1:30 ^b | Rapid sedimentation of protein precipitates, large particles, cells and cell debris, as well as binding studies and separating serum from whole blood. |

¹ Accel times are approximate and subject to change.

^a Typical accel time in Avanti J-25 Series.

^b Typical accel time in Avanti J-26 XP Series.

^c Typical accel time in Avanti J-301 (JS rotors using mandatory slow accel setting).

^d Typical accel time in Avanti J-E.

High-Performance/High-Capacity Centrifugation

1

High-Performance and High-Capacity Rotor Summary (continued)

| Rotor Type | Part Number | Maximum Speed (rpm) | Maximum Force at r_{min} (g) | Maximum Force at r_{max} (g) | k Factor | Number Tubes/Bottles and Size (diameter x length) | Rotor Capacity (mL) | Approx. Accel. Time ¹ (min:sec) | Comments |
|-----------------------------------|-------------------------------|---------------------|--------------------------------|--------------------------------|----------|---|---------------------|--|---|
| Continuous-Flow Rotor | | | | | | | | | |
| JCF-Z | 335140 (standard core) | 20 000 | 32 000 | 39 900 | 100 | Not applicable | 660 mL | N.A. | Purification of viruses and/or concentration of large volumes of solution. Pelleting or sedimenting on a sucrose cushion. Maximum pellet size: 400 mL. |
| | 357544 (small pellet core) | 20 000 | 23 300 | 36 300 | 281 | Not applicable | 240 mL | N.A. | Pelleting liquids that contain a low ratio of solids—such as bacterial cultures, or water containing clay particles or algae. Maximum pellet size: 200 mL. |
| | 357521 (large pellet core) | 20 000 | 22 850 | 39 900 | 293 | Not applicable | 1 250 mL | N.A. | Pelleting solutions that have high solid-to-water ratios as high as 1:2 slurries. Maximum pellet size: 800 mL. |
| Zonal Rotor | | | | | | | | | |
| JCF-Z | 354006 | 20 000 | 9 000 | 39 900 | 710 | 69 mm | 1 990 mL | N.A. | Fast start up. Dynamic loading and unloading. Isopycnic banding, linear, and discontinuous gradients. Subcellular fractions from tissue homogenates, algae, and chloroplasts. |
| Reorienting Gradient Rotor | | | | | | | | | |
| JCF-Z | 354005 | 20 000 | 11 650 | 39 900 | 779 | 63 mm | 1 750 mL | N.A. | No rotating seal. Static loading and unloading. Gradient reorients in rotor. Especially useful for fragile material such as DNA strands. |

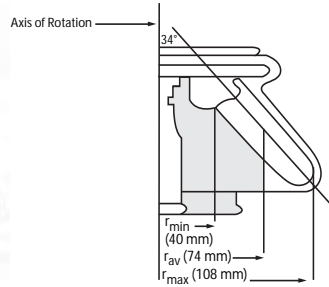

Fixed-Angle Rotor, Titanium

Major applications: Harvesting bacteria, processing tissue homogenates, subcellular particulates, routine pelleting such as precipitates and phase separations.

| Max. RPM | Max. <i>g</i> | <i>k</i> Factor | Number of Tubes Volume/Size | Rotor Capacity |
|----------|---------------|-----------------|--|----------------|
| 30 000 | 108 860 | 280 | 8 × 50 mL 29 × 104 mm 1.125 × 4 in | 400 mL |

For use in Avanti® J Series centrifuges (except Avanti J-E and J-HC) and J2 Series centrifuges.

- No. 363420. JA-30.50 Fixed-Angle Ti Rotor with Biosafety Lid.
- No. 363421. JA-30.50 Fixed-Angle Ti Rotor with Single Lock Lid.

Tubes and Bottles

| Tube Style/Material | Nominal Volume per Tube (mL) | Part No. | Quantity | Size (mm) | Required Adapters | Tubes per Adapter | <i>g</i> -Force | <i>k</i> Factor | Maximum Speed |
|------------------------------------|------------------------------|----------|----------|-----------|-------------------|-------------------|-----------------|-----------------|---------------|
| Bottles with Screw Caps | | | | | | | | | |
| Polyallomer | 50.0 | 357003 | 25 | 29 x 104 | ----- | ----- | 75 600 | 403 | 25 000 |
| Polycarbonate | 10.0 | 355672 | 25 | 16 x 80 | 361703† | 1 | 91 000 | 244 | 30 000 |
| | 50.0 | 357002 | 25 | 29 x 104 | ----- | ----- | 75 600 | 403 | 25 000 |
| Bottles with Cap Assemblies | | | | | | | | | |
| Polyallomer | 50.0 | 357001 | 6 | 29 x 104 | ----- | ----- | 108 900 | 280 | 30 000* |
| Polycarbonate | 50.0 | 357000 | 6 | 29 x 104 | ----- | ----- | 108 900 | 280 | 30 000 |
| Tubes with Snap-On Caps | | | | | | | | | |
| Polyallomer | 1.5 | 357448 | 500 | 11 x 38 | 361705† | 3 | 73 400 | 126 | 30 000 |
| Thickwall Polycarbonate | 50.0 | 363664 | 25 | 29 x 104 | ----- | ----- | 75 600 | 403 | 25 000 |
| Polypropylene | 1.5 | 356090 | 500 | 11 x 38 | 361705† | 3 | 73 400 | 126 | 30 000 |
| Thickwall Polypropylene | 50.0 | 357005 | 25 | 29 x 104 | ----- | ----- | 75 600 | 403 | 25 000 |
| Open-Top Tubes | | | | | | | | | |
| Thickwall Polycarbonate | 50.0 | 363647 | 25 | 29 x 104 | ----- | ----- | 108 900 | 280 | 30 000* |
| Thickwall Polypropylene | 50.0 | 357007 | 25 | 29 x 104 | ----- | ----- | 108 900 | 280 | 30 000 |

* At 2°C; at 25°C, maximum speed must be limited to 26 000 rpm for tube 357001 and 29 000 rpm for tube 363647.
† Set of 2.

Rotor Replacement Parts

- 870612 O-ring for Rotor Lid
- 011757 Small O-ring for Rotor Lid
- 363424 Lid Assembly, Biosafety (tie-down assembly included)
- 363430 Lid Assembly, Single-lock
- 363431 Tie-down for Single-locking Lid

Adapters

See chart on page 2-6 for adapters used with non-Beckman Coulter tubes and bottles.

361703 361705



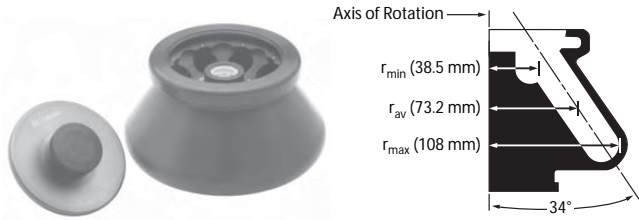

Fixed-Angle Rotor, Aluminum

Major applications: Harvesting bacteria, processing tissue homogenates, subcellular particulates, routine pelleting such as precipitates and phase separations.

| Max. RPM | Max. g | k Factor | Number of Tubes Volume/Size | Rotor Capacity |
|----------|--------|----------|--|----------------|
| 25 000 | 75 600 | 418 | 8 x 50 mL 29 x 104 mm 1.125 x 4 in | 400 mL |

For use in Avanti® J Series and J2 Series centrifuges.

- No. 363058. JA-25.50 Fixed-Angle Rotor with Biosafety Lid.
- No. 363055. JA-25.50 Fixed-Angle Rotor with Single Lock Lid.

Tubes and Bottles

| Tube Style/Material | Nominal Volume per Tube (mL) | Part No. | Quantity | Size (mm) | Required Adapters | Tubes per Adapter | g-Force | k Factor | Maximum Speed |
|------------------------------------|------------------------------|----------|----------|-----------|-------------------|-------------------|---------|----------|---------------|
| Bottles with Screw Caps | | | | | | | | | |
| Polyallomer | 50.0 | 357003 | 25 | 29 x 104 | ----- | ----- | 75 600 | 418 | 25 000 |
| Polycarbonate | 10.0 | 355672 | 25 | 16 x 80 | 361703† | 1 | 63 240 | 350 | 25 000 |
| | 50.0 | 357002 | 25 | 29 x 104 | ----- | ----- | 75 600 | 418 | 25 000 |
| Bottles with Cap Assemblies | | | | | | | | | |
| Polyallomer | 50.0 | 361694 | 24 | 29 x 104 | ----- | ----- | 75 600 | 418 | 25 000 |
| Polycarbonate | 50.0 | 361693 | 24 | 29 x 104 | ----- | ----- | 75 600 | 418 | 25 000 |
| Tubes with Snap-On Caps | | | | | | | | | |
| Thickwall Polycarbonate | 50.0 | 363664* | 25 | 29 x 104 | ----- | ----- | 75 600 | 418 | 25 000 |
| Thickwall Polypropylene | 1.5 | 356090 | 500 | 11 x 38 | 361705† | 3 | 50 960 | 182 | 25 000 |
| | 50.0 | 357005* | 25 | 29 x 104 | ----- | ----- | 75 600 | 418 | 25 000 |
| Open-Top Tubes | | | | | | | | | |
| Polyallomer | 1.5 | 357448 | 500 | 11 x 38 | 361705† | 3 | 50 960 | 182 | 25 000 |
| Thickwall Polycarbonate | 50.0 | 363647 | 25 | 29 x 104 | ----- | ----- | 75 600 | 418 | 25 000 |
| Thickwall Polypropylene | 50.0 | 357007 | 25 | 29 x 104 | ----- | ----- | 75 600 | 418 | 25 000 |

* Order cap separately (pkg. of 25): 356264 (natural), 357359 (red), 357360 (green), 357361 (yellow), or 357362 (blue).
† Set of 2.

Rotor Replacement Parts

- 870612 O-ring for Rotor Lid
- 011757 Small O-ring for Rotor Lid
- 363023 Lid Assembly, Biosafety (Tie-down Assembly included)
- 363053 Lid Assembly, Single Lock (Tie-down Assembly included)

Adapters

See chart on page 2–6 for adapters used with non-Beckman Coulter tubes and bottles.

361703 361705



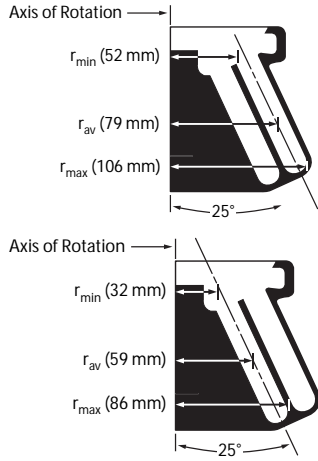

Fixed-Angle Rotor, Aluminum

Major applications: Harvesting bacteria, processing tissue homogenates, subcellular particulates, routine pelleting such as precipitates and phase separations.

| | Max. RPM | Max. <i>g</i> | <i>k</i> Factor | Number of Tubes Volume/Size | Rotor Capacity |
|-----------|----------|---------------|-----------------|--------------------------------|-------------------|
| Outer Row | 25 000 | 74 200 | 265 | 24 x 15 mL 18 x 100 mm | 360 mL |
| Inner Row | 25 000 | 60 200 | 380 | 0.75 x 4 in | |

*For use in Avanti® J Series centrifuges
(except Avanti J-E) and J2 Series centrifuges.*

No. 363050. JA-25.15 Fixed-Angle Rotor with Biosafety Lid.
No. 363054. JA-25.15 Fixed-Angle Rotor, Single Lock Lid.

Tubes and Bottles

| Tube Style/Material | Nominal Volume per Tube (mL) | Part No. | Quantity | Size (mm) | Required Adapters | Tubes per Adapter | <i>g</i> -Force | <i>k</i> Factor | Maximum Speed |
|--------------------------------|------------------------------|----------|----------|-----------|-------------------|-------------------|-----------------|-----------------|---------------|
| Bottles with Screw Caps | | | | | | | | | |
| Polycarbonate | 4.0 | 355672 | 25 | 16 x 80 | 342327 | 1 | 60 200 | 204 | 25 000 |
| Open-Top Tube | | | | | | | | | |
| Thickwall Polyallomer | 4.0 | 355644 | 25 | 13 x 64 | 303313 | 1 | 49 000 | 120 | 25 000 |
| | 10.0 | 355640 | 25 | 16 x 76 | 342327 | 1 | 56 700 | 180 | 25 000 |
| Polycarbonate | 15.0 | 342080 | 100 | 18 x 98 | ----- | ----- | 74 200 | 265 | 25 000 |
| Thickwall Polycarbonate* | 4.0 | 355645 | 25 | 13 x 64 | 303313 | 1 | 49 000 | 120 | 25 000 |
| | 10.0 | 355630 | 25 | 16 x 76 | 342327 | 1 | 56 700 | 180 | 25 000 |
| Polyethylene* | 15.0 | 342081 | 100 | 18 x 98 | ----- | ----- | 74 200 | 265 | 25 000 |
| Polypropylene* | 15.0 | 342082 | 100 | 18 x 98 | ----- | ----- | 74 200 | 265 | 25 000 |

* To order caps for 15-mL tubes 342080, 342081, and 342082, use part number 343656 for a package of 50.

Rotor Replacement Parts

- 964911 Large O-ring for Rotor Lid
- 011757 Small O-ring for Rotor Lid
- 363024 Lid Assembly, Biosafety (Tie-down Assembly included)
- 363052 Rotor Lid Assembly, Single Lock (Tie-down Assembly included)

Adapters

See chart on page 2-6 for adapters used with non-Beckman Coulter tubes and bottles.

303313 342327



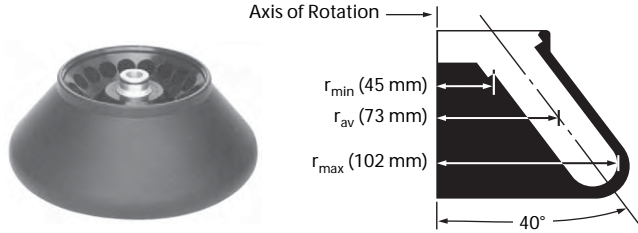

Fixed-Angle Rotor, Aluminum

Major applications: Rapid, efficient separation of many samples in small volumes, such as viruses, bacteriophage, mitochondria, and nuclei.

| Max. RPM | Max. <i>g</i> | <i>k</i> Factor | Number of Tubes Volume/Size | Rotor Capacity |
|----------|---------------|-----------------|--|----------------|
| 21 000 | 50 400 | 470 | 18 x 10 mL 16 x 80 mm 0.625 x 3 in | 180 mL |

For use in Avanti® J Series and J2 Series centrifuges.

No. 334845. JA-21 Fixed-Angle Rotor for 21 000 rpm operation.

Tubes and Bottles

| Tube Style/Material | Nominal Volume per Tube (mL) | Part No. | Quantity | Size (mm) | Required Adapters | Tubes per Adapter | <i>g</i> -Force | <i>k</i> Factor | Maximum Speed |
|--------------------------------|------------------------------------|----------|----------|--------------|----------------------|----------------------|-----------------|-----------------|------------------|
| Bottles with Screw Caps | | | | | | | | | |
| Polycarbonate | 10.0 | 355672 | 25 | 16 x 80 | --- | --- | 50 400 | 469 | 21 000 |
| Open-Top Tubes | | | | | | | | | |
| Thickwall Polyallomer | 10.0 | 355640 | 25 | 16 x 76 | --- | --- | 50 400 | 470 | 21 000 |
| Thickwall Polycarbonate | 10.0 | 355630 | 25 | 16 x 76 | --- | --- | 50 400 | 470 | 21 000 |

See chart on page 2–6 for adapters used with non-Beckman Coulter tubes and bottles.

Rotor Replacement Parts

- 870612 O-ring for Rotor Lid
- 870980 O-ring for Rotor Hub
- 343631 Lid Attachment Bolt Assembly
- 369349 Rotor Lid Assembly (Tie-down Assembly included)

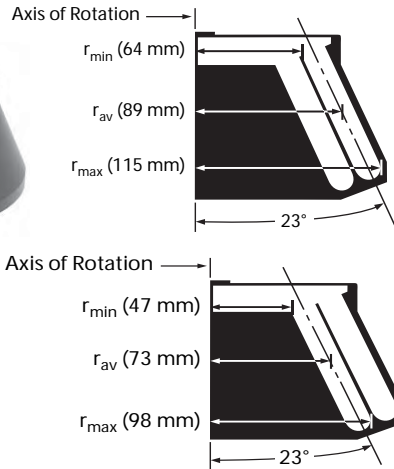

Fixed-Angle Rotor, Aluminum

Major applications: High-force, large-volume separation of particles with 100 S or larger sedimentation coefficients.

| | Max. RPM | Max. g | k Factor | Number of Tubes Volume/Size | Rotor Capacity |
|-----------|----------|--------|----------|--------------------------------|-------------------|
| Outer Row | 20 000 | 51 500 | 371 | 32 x 15 mL 18 x 99 mm | 480 mL |
| Inner Row | 20 000 | 43 900 | 465 | 0.625 x 4 in | |

For use in Avanti® J Series and J2 Series centrifuges.

No. 342095. JA-20.1 Fixed-Angle Biosafety Rotor for 20 000 rpm operation.

Tubes and Bottles

| Tube Style/Material | Nominal Volume per Tube (mL) | Part No. | Quantity | Size (mm) | Required Adapters | Tubes per Adapter | g-Force | k Factor* | Maximum Speed |
|--------------------------------|------------------------------------|----------|----------|--------------|----------------------|----------------------|---------|-----------|------------------|
| Bottles with Screw Caps | | | | | | | | | |
| Polycarbonate | 10.0 | 355672 | 25 | 16 x 80 | 342327 | 1 | 47 900 | 325 | 20 000 |
| Open-Top Tubes | | | | | | | | | |
| Thickwall Polyallomer | 10.0 | 355640 | 25 | 16 x 76 | 342327 | 1 | 47 900 | 325 | 20 000 |
| Thickwall Polycarbonate | 10.0 | 355630 | 25 | 16 x 76 | 342327 | 1 | 47 900 | 325 | 20 000 |
| | 15.0 | 342080 | 100 | 18 x 98 | ----- | ----- | 51 500 | 371 | 20 000 |
| Thickwall Polyethylene | 15.0 | 342081 | 100 | 18 x 98 | ----- | ----- | 51 500 | 371 | 20 000 |
| Thickwall Polypropylene | 15.0 | 342082 | 100 | 18 x 98 | ----- | ----- | 51 500 | 371 | 20 000 |
| Stainless Steel | 10.0 | 301108 | 1 | 16 x 76 | 342327 | 1 | 47 900 | 325 | 20 000 |

Rotor Supplies

- 338896 Rotor Removal Tool
- 338689 Adapter Collar for 338896 Rotor Removal Tool

Caps for 15-mL Tubes

- 343656 Caps (box of 50) for 342080, 342081, and 342082 Tubes

Rotor Replacement Parts

- 834301 O-ring for Rotor Lid
- 870980 O-ring for Rotor Hub
- 358368 Lid Attachment Bolt Assembly
- 341976 Rotor Lid
- 364915 Tie-down Kit
- 392889 Hold-down Knob, for use with filtration tubes regularly run without lid (in J2/J6 centrifuges only)

* Measured using the outer row of tubes.

Adapters

See chart on page 2-6 for adapters used with non-Beckman Coulter tubes and bottles.

342327



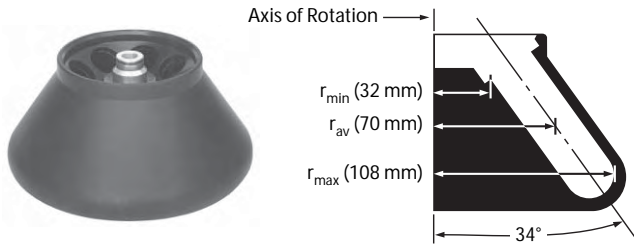

Fixed-Angle Rotor, Aluminum

Major applications: Harvesting bacteria and cell membranes, processing tissue homogenates, separating cell particulates.

| Max. RPM | Max. <i>g</i> | <i>k</i> Factor | Number of Tubes Volume/Size | Rotor Capacity |
|----------|---------------|-----------------|--|----------------|
| 20 000 | 48 400 | 770 | 8 x 50 mL 29 x 104 mm 1.125 x 4 in | 400 mL |

For use in Avanti® J Series and J2 Series centrifuges.

No. 334831. JA-20 Fixed-Angle Biosafety Rotor for 20 000 rpm operation.

Tubes and Bottles

| Tube Style/Material | Nominal Volume per Tube (mL) | Part No. | Quantity | Size (mm) | Required Adapters | Tubes per Adapter | <i>g</i> -Force | <i>k</i> Factor | Maximum Speed |
|--------------------------------|------------------------------|----------|----------|-----------|-------------------|-------------------|-----------------|-----------------|---------------|
| Bottles with Screw Caps | | | | | | | | | |
| Polyethylene | 50.0 | 357003 | 25 | 29 x 104 | ----- | ----- | 48 400 | 770 | 20 000 |
| Polycarbonate | 10.0 | 355672 | 25 | 16 x 80 | 342327/870329 | 1 | 43 500 | 650 | 20 000 |
| | 50.0 | 357002 | 25 | 29 x 104 | ----- | ----- | 48 400 | 770 | 20 000 |

Bottles with Cap Assemblies

| | | | | | | | | | |
|---------------|------|--------|---|----------|-------|-------|--------|-----|--------|
| Polyallomer | 50.0 | 357001 | 6 | 29 x 104 | ----- | ----- | 48 400 | 770 | 20 000 |
| Polycarbonate | 50.0 | 357000 | 6 | 29 x 104 | ----- | ----- | 48 400 | 770 | 20 000 |

Tubes with Snap-On Caps

| | | | | | | | | | | |
|-------------------------|---------|------|--------|-----|----------|---------|-------|---------|-----|--------|
| Polyallomer | Natural | 1.5 | 357448 | 500 | 11 x 38 | 344497* | 6 | 48 400 | 770 | 20 000 |
| Thickwall Polycarbonate | | 50.0 | 363664 | 25 | 29 x 104 | ----- | ----- | 48 400 | 770 | 20 000 |
| Polyethylene | | 1.8 | 340196 | 500 | 11 x 39 | 344497* | 6 | 48 400† | 770 | 20 000 |
| Thickwall Polypropylene | | 50.0 | 357005 | 25 | 29 x 104 | ----- | ----- | 48 400 | 770 | 20 000 |
| | Orange | 1.5 | 356094 | 500 | 11 x 38 | 344497* | 6 | 48 400 | 770 | 20 000 |
| | Yellow | 1.5 | 356093 | 500 | 11 x 38 | 344497* | 6 | 48 400 | 770 | 20 000 |
| | Green | 1.5 | 356092 | 500 | 11 x 38 | 344497* | 6 | 48 400 | 770 | 20 000 |
| | Blue | 1.5 | 356091 | 500 | 11 x 38 | 344497* | 6 | 48 400 | 770 | 20 000 |
| | Natural | 1.5 | 356090 | 500 | 11 x 38 | 344497* | 6 | 48 400 | 770 | 20 000 |

Open-Top Tubes

| | | | | | | | | | | |
|-------------------------|--|------|--------|----|----------|-------|-------|--------|-----|--------|
| Thickwall Polypropylene | | 50.0 | 363647 | 25 | 29 x 104 | ----- | ----- | 48 400 | 770 | 20 000 |
|-------------------------|--|------|--------|----|----------|-------|-------|--------|-----|--------|

Rotor Supplies

- 346965 Rotor Removal Tool
- 338689 Adapter Collar for 346965 Rotor Removal Tool

Cap Assembly Replacement Parts

- 356284 Cap for 357000 and 357001 Bottle
- 358627 Insert for 357000 and 357001 Cap Assembly; order only as a replacement part
- 961582 O-ring for 357000 and 357001 Bottle

Rotor Replacement Parts

- 870612 O-ring for Rotor Lid
- 811656 O-ring for Rotor Hub
- 364914 Tie-down Kit
- 369349 Rotor Lid
- 392889 Hold-down Knob, for use with filtration tubes regularly run without lid (in J2/J6 centrifuges only)

* Can be double-stacked. Force will vary depending on tube position.
† Calculated at r_{max}, *g*-force will be less for tubes located in upper adapter when adapters are stacked. Force will also vary depending on tube position in adapter.

Adapters

See chart on page 2-6 for adapters used with non-Beckman Coulter tubes and bottles.

342327 344497 870329



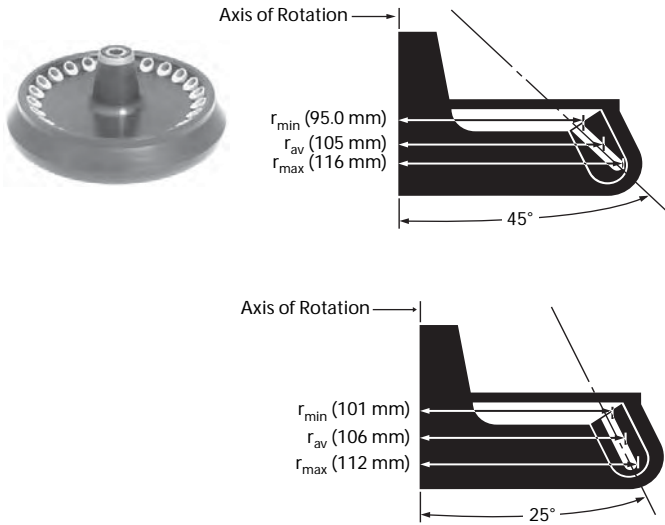

Fixed-Angle Rotor, Aluminum

Major applications: High-force sedimentation in microcentrifuge tubes under refrigerated conditions.

| Max. RPM at 45° Angle* | Max. g | k Factor | Number of Tubes Volume/Size | Rotor Capacity |
|------------------------|--------|----------|--|----------------|
| 18 000 | 42 100 | 156 | 24 x 1.8 mL 11 x 38 mm 0.4 x 1.5 in. | 43.2 mL |

| Max. RPM at 25° Angle* | Max. g | k Factor | Number of Tubes Volume/Size | Rotor Capacity |
|------------------------|--------|----------|--|----------------|
| 17 000 | 36 300 | 91 | 24 x 1.8 mL 11 x 38 mm 0.4 x 1.5 in. | 43.2 mL |

For use in Avanti® J Series and J2 Series centrifuges (except Avanti J-E).

No. 347824. JA-18.1 Fixed-Angle Rotor. Includes 24 reversible adapters that provide 18 000 rpm maximum speed. In the J2-HC centrifuge: 15 000 rpm maximum speed at 45° angle and 16 000 rpm maximum speed at 25° angle. Tubes are not included.

Tubes and Bottles

| Tube Style/Material | Nominal Volume per Tube (mL) | Part No. | Quantity | Size (mm) | Required Adapters | Tubes per Adapter† | g-Force | k Factor | Maximum Speed* | |
|--------------------------------|------------------------------|----------|----------|-----------|-------------------|--------------------|---------|----------|----------------|--------|
| Tubes with Snap-On Caps | | | | | | | | | | |
| Polyallomer | Natural | 1.5 | 357448 | 500 | 11 x 38 | 347562 | 1 | 42 100 | ----- | 18 000 |
| Polyethylene | | 1.8 | 340196 | 500 | 11 x 39 | 347562 | 1 | 42 100 | ----- | 18 000 |
| Polypropylene | Orange | 1.5 | 356094 | 500 | 11 x 38 | 347562 | 1 | 42 100 | ----- | 18 000 |
| | Yellow | 1.5 | 356093 | 500 | 11 x 38 | 347562 | 1 | 42 100 | ----- | 18 000 |
| | Green | 1.5 | 356092 | 500 | 11 x 38 | 347562 | 1 | 42 100 | ----- | 18 000 |
| | Blue | 1.5 | 356091 | 500 | 11 x 38 | 347562 | 1 | 42 100 | ----- | 18 000 |
| | Natural | 1.5 | 356090 | 500 | 11 x 38 | 347562 | 1 | 42 100 | ----- | 18 000 |
| | Natural‡ | 1.5 | 343169 | 500 | 11 x 38 | 347562 | 1 | 42 100 | ----- | 18 000 |

* In the J2-HC, maximum speeds are reduced to 15 000 rpm at 45° angle and 16 000 rpm at 25° angle.

† Adapters are reversible, so that tube angle can be set at either 45° or 25°, depending on application requirements.

‡ With separate cap.

Rotor Replacement Parts

| | |
|--------|---------------------|
| 011921 | O-ring |
| 335112 | Washer |
| 347821 | Rotor Knob Assembly |
| 364918 | Tie-down Kit |

Adapters

See chart on page 2-6 for adapters used with non-Beckman Coulter tubes and bottles.

347562



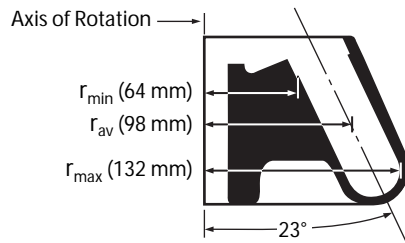

Fixed-Angle Rotor, Aluminum

Major applications: High-force, large-volume. Pelleting bacteria, cell membranes, and subcellular organelles.

| Max. RPM | Max. <i>g</i> | <i>k</i> Factor | Number of Tubes Volume/Size | Rotor Capacity |
|--|---------------|-----------------|--|----------------|
| 18 000 (16 000 rpm at 4°C and below) | 47 900 | 566 | 10 x 100 mL 38 x 102 mm 1.5 x 4 in | 1 L |

For use in Avanti® J Series and J2 Series centrifuges.

No. 369679. JA-18 Fixed-Angle Biosafety Rotor for 18 000 rpm operation.

Tubes and bottles not included.

Tubes and Bottles

| Tube Style/Material | Nominal Volume per Tube (mL) | Part No. | Quantity | Size (mm) | Required Adapters | Tubes per Adapter | <i>g</i> -Force | <i>k</i> Factor | Maximum Speed | |
|------------------------------------|------------------------------|----------|----------|-----------|-------------------|-------------------|-----------------|-----------------|---------------|--------|
| Quick-Seal® Tubes | | | | | | | | | | |
| Polyallomer | 100.0 | 345776 | 25 | 38 x 102 | ---- | ---- | 47 900 | 566 | 18 000 | |
| Ultra-Clear™ | 100.0 | 345778 | 25 | 38 x 102 | ---- | ---- | 47 900 | 566 | 18 000 | |
| Bottles with Cap Assemblies | | | | | | | | | | |
| Polycarbonate | 70.0 | 355620 | 6 | 38 x 102 | ---- | ---- | 47 900 | 566 | 18 000 | |
| Polypropylene | 94.0 | 355624 | 6 | 38 x 102 | ---- | ---- | 47 900 | 566 | 18 000 | |
| Bottles with Screw Caps | | | | | | | | | | |
| Polyallomer | 50.0 | 357003 | 25 | 29 x 104 | 347539 | 1 | 44 000 | ---- | 18 000 | |
| Polycarbonate | 50.0 | 357002 | 25 | 29 x 104 | 347539 | 1 | 44 000 | ---- | 18 000 | |
| Tubes with Snap-On Caps | | | | | | | | | | |
| Polyallomer | Natural | 1.5 | 357448 | 500 | 11 x 38 | 344497/347539† | 6 | 35 000 | ---- | 18 000 |
| Polyethylene | | 1.8 | 340196 | 500 | 11 x 39 | 344497/347539† | 6 | 35 000 | ---- | 18 000 |
| Polypropylene | Orange | 1.5 | 356094 | 500 | 11 x 38 | 344497/347539† | 6 | 35 000 | ---- | 18 000 |
| | Yellow | 1.5 | 356093 | 500 | 11 x 38 | 344497/347539† | 6 | 35 000 | ---- | 18 000 |
| | Green | 1.5 | 356092 | 500 | 11 x 38 | 344497/347539† | 6 | 35 000 | ---- | 18 000 |
| | Blue | 1.5 | 356091 | 500 | 11 x 38 | 344497/347539† | 6 | 35 000 | ---- | 18 000 |
| | Natural | 1.5 | 356090 | 500 | 11 x 38 | 344497/347539† | 6 | 35 000 | ---- | 18 000 |
| | Natural‡ | 1.5 | 343169 | 500 | 11 x 38 | 344497† | 6 | 35 000 | ---- | 18 000 |
| Open-Top Tubes | | | | | | | | | | |
| Polycarbonate* | 50.0 | 363647 | 25 | 29 x 104 | 347539 | 1 | 47 900 | 566 | 18 000 | |
| Polypropylene* | 50.0 | 357007 | 25 | 29 x 104 | 347539 | 1 | 47 900 | 566 | 18 000 | |

* A cap is available for these tubes, but it cannot be used in the JA-18 rotor; for a cap to use when storing samples, order cap 356262.

† Can be double-stacked. Force will vary depending on tube position.

‡ With separate cap.

Rotor Replacement Parts

| | |
|--------|------------------------|
| 346947 | Tie-down Bolt Assembly |
| 346965 | Rotor Removal Tool |
| 364845 | Rotor Lid Assembly |
| 364917 | Tie-down Kit |

Adapters

See chart on page 2–6 for adapters used with non-Beckman Coulter tubes and bottles.

344497 347539



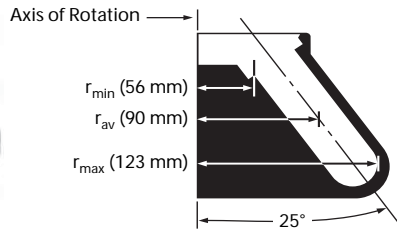

Fixed-Angle Rotor, Aluminum

Major applications: High-force, large-volume. Pelletting bacteria, cell membranes, and subcellular organelles.

| Max. RPM | Max. <i>g</i> | <i>k</i> Factor | Number of Tubes Volume/Size | Rotor Capacity |
|----------|---------------|-----------------|---|----------------|
| 17 000 | 39 800 | 690 | 14 x 50 mL 29 x 104 mm 1.125 x 4 in | 700 mL |

For use in Avanti® J Series and J2 Series centrifuges.

No. 369691. JA-17 Fixed-Angle Biosafety Rotor.
Tubes and bottles not included.

Tubes and Bottles

| Tube Style/Material | Nominal Volume per Tube (mL) | Part No. | Quantity | Size (mm) | Required Adapters | Tubes per Adapter | <i>g</i> -Force | <i>k</i> Factor | Maximum Speed |
|------------------------------------|------------------------------|----------|----------|-----------|-------------------|-------------------|-----------------|-----------------|---------------|
| Bottles with Cap Assemblies | | | | | | | | | |
| Polyallomer | 50.0 | 357001 | 6 | 29 x 104 | ---- | ---- | 39 800 | 690 | 17 000 |
| | 50.0 | 361694 | 24 | 29 x 104 | ---- | ---- | 39 800 | 690 | 17 000 |
| Polycarbonate | 50.0 | 357000 | 6 | 29 x 104 | ---- | ---- | 39 800 | 690 | 17 000 |
| | 50.0 | 361693 | 24 | 29 x 104 | ---- | ---- | 39 800 | 690 | 17 000 |
| Bottles with Screw Caps | | | | | | | | | |
| Polyallomer | 50.0 | 357003 | 25 | 29 x 104 | ---- | ---- | 39 800 | 690 | 17 000 |
| Polycarbonate | 10.0 | 355672 | 25 | 16 x 80 | 342327/870329 | 1 | 32 000 | ---- | 17 000 |
| | 50.0 | 357002 | 25 | 29 x 104 | ---- | ---- | 39 800 | 690 | 17 000 |
| Tubes with Snap-On Caps | | | | | | | | | |
| Polypropylene | 50.0 | 357005† | 25 | 29 x 104 | ---- | ---- | 39 800* | 690 | 17 000 |
| Tubes without Caps | | | | | | | | | |
| Thickwall Polycarbonate | 50.0 | 363647 | 25 | 29 x 104 | ---- | ---- | 39 800 | 690 | 17 000 |
| Thickwall Polypropylene | 50.0 | 357007 | 25 | 29 x 104 | ---- | ---- | 39 800 | 689 | 17 000 |

Rotor Supplies

- 346965 Rotor Removal Tool
- 338689 Adapter Collar for 346945 Rotor Removal Tool

Cap Assembly Replacement Parts

- 356284 Cap for 357000 and 357001 Tubes
- 358627 Insert for 357000 and 357001 Cap Assembly; order only for use in tubes
- 961582 O-ring for 357000 and 357001 Cap Assembly

Rotor Replacement Parts

- 878951 O-ring for Rotor Lid
- 811656 O-ring for Rotor Hub
- 358367 Lid Attachment Bolt Assembly
- 364913 Tie-down Kit
- 341926 Rotor Lid
- 392889 Hold-down Knob
(used to run filtration tubes without lid)

* Can be double-stacked. Force will vary depending on position of tube in adapter.
† A maximum of seven tubes can be used, placed in every other rotor hole (tubes placed in adjacent holes will hit one another).
‡ With separate cap.

Adapters

See chart on page 2–6 for adapters used with non-Beckman Coulter tubes and bottles.

- 342327 344497 870329



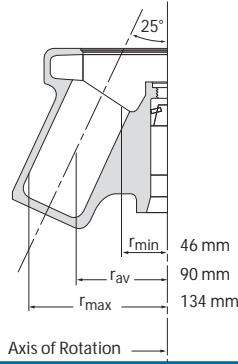

Fixed-Angle Rotor, Aluminum

Major applications: General purpose, large-volume and multitube processing. Lightweight alternative to conventional 6 x 250 rotors; empty rotor weight is 10.3 kg (22.7 lb).

| Max. RPM | Max. g | k Factor | Number of Tubes Volume/Size | Rotor Capacity |
|----------|--------|----------|---|----------------|
| 16 000* | 38 420 | 1 060 | 6 x 250 mL 62 x 120 mm 2.5 x 5.5 in | 1.5 L |

For use in Avanti® J Series and J2 Series centrifuges.

No. 363930. J-Lite® JLA-16.250 Rotor Assembly with Biosafety Lid.

No. 363934. Rotor Assembly with Single Lock Lid.

Tubes and Bottles

| Tube Style/Material | Nominal Volume per Tube (mL) | Part No. | Quantity | Size (mm) | Required Adapters | Tubes per Adapter | g-Force | k Factor | Maximum Speed* |
|----------------------------------|------------------------------|----------|----------|-----------|-------------------|-------------------|---------|----------|----------------|
| Bottles with Screw Caps | | | | | | | | | |
| Polyallomer | 38.5 | 357003 | 25 | 29 x 104 | 356997 | 1 | 32 200 | 650 | 16 000 |
| Polycarbonate | 38.5 | 357002 | 25 | 29 x 104 | 356997 | 1 | 32 200 | 660 | 16 000 |
| Bottles with Cap Assembly | | | | | | | | | |
| Polyallomer | 40.0 | 357001 | 6 | 29 x 104 | 356997 | 1 | 32 200 | 650 | 16 000 |
| Polycarbonate | 40.0 | 357000 | 6 | 29 x 104 | 356997 | 1 | 32 200 | 660 | 16 000 |
| Wide-mouth Polycarbonate | 250.0 | 356013 | 6 | 62 x 120 | --- | --- | 38 420 | 1 060 | 16 000 |
| Wide-mouth Polypropylene | 250.0 | 356011 | 6 | 62 x 120 | --- | --- | 38 420 | 1 060 | 16 000 |
| Tubes with Snap-On Caps | | | | | | | | | |
| Polycarbonate | 36.0 | 363664 | 25 | 29 x 104 | 356997 | 1 | 32 100 | 400 | 16 000 |
| Polypropylene | 36.0 | 357005 | 25 | 29 x 104 | 356997 | 1 | 32 100 | 400 | 16 000 |
| BioVials | | | | | | | | | |
| Polypropylene | 4.0 | 566353 | 1000 | 14 x 55 | 342098 | 9 | 2 300 | 10 700 | 4 000 |

* The maximum speed is 14 000 rpm in J2 Series centrifuges.

Rotor Replacement Parts

- 363931 Double-locking Lid Assembly
- 363935 Single-locking Lid Assembly
- 893502 Large O-ring for Either Lid Assembly (5.987 dia.)
- 893503 Small O-ring for Either Lid Assembly (1.046 dia.)

Adapters

See chart on page 2-6 for adapters used with non-Beckman Coulter tubes and bottles.



F14BCI-6x250y

6 x 250 mL

F14BCI-6x250y

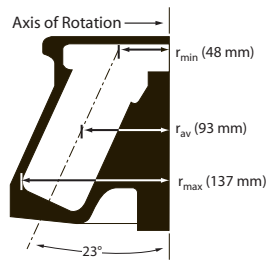

Carbon Fiber Rotor

Major applications: Large-volume for initial processing of bacteria or other cells from fermentors, clearing cell debris from homogenates, or pelleting subcellular organelles and protein precipitates.

| Max. RPM | Max. <i>g</i> | <i>k</i> Factor | Number of Tubes Volume/Size | Rotor Capacity |
|----------|---------------|-----------------|--|----------------|
| 14 000 | 30 000 | 1 690 | 6 x 250 mL 62 x 120 mm 2.45 x 4.8 in | 1.5 L |

For use in Avanti® J Series centrifuges
(except Avanti J-HC).

No. A39751. F14BCI-6x250y rotor.

Tubes and Bottles

| Tube Style/Material | Nominal Volume per Tube (mL) | Part No. | Quantity | Size (mm) | Required Adapters | Tubes per Adapter | <i>g</i> -Force | <i>k</i> Factor | Maximum Speed |
|---|------------------------------|----------|----------|-----------|-------------------|-------------------|-----------------|-----------------|---------------|
| Bottles with Cap Assemblies | | | | | | | | | |
| Polyallomer | 50.0 | 357001 | 6 | 29 x 104 | A39759 | 1 | 30 000 | ----- | 14 000 |
| Polycarbonate | 50.0 | 357000 | 6 | 29 x 104 | A39759 | 1 | 30 000 | ----- | 14 000 |
| Wide-mouth Polycarbonate | 250.0 | 358275 | 6 | 62 x 120 | ----- | ----- | 30 000 | ----- | 14 000 |
| Wide-mouth Polypropylene | 250.0 | 358326 | 6 | 62 x 120 | ----- | ----- | 30 000 | ----- | 14 000 |
| Bottles with Screw Caps | | | | | | | | | |
| Polyallomer | 50.0 | 357003 | 25 | 29 x 104 | A39759 | 1 | 30 000 | ----- | 14 000 |
| Conical Wide-mouth Polyallomer | 230.0 | 356989 | 6 | 60 x 130 | 356983 | 1 | 8 600 | ----- | 7 500 |
| Polycarbonate | 50.0 | 357002 | 25 | 29 x 104 | A39759 | 1 | 30 000 | ----- | 14 000 |
| Wide-mouth Polycarbonate | 250.0 | 356013 | 6 | 62 x 120 | ----- | ----- | 30 000 | ----- | 14 000 |
| Conical Wide-mouth Polycarbonate | 230.0 | 356987 | 6 | 60 x 130 | 356983 | 1 | 8 600 | ----- | 7 500 |
| Wide-mouth Polypropylene | 250.0 | 356011 | 6 | 62 x 120 | ----- | ----- | 30 000 | ----- | 14 000 |
| Tubes with Snap-On Caps | | | | | | | | | |
| Polycarbonate | 50.0 | 363664 | 25 | 29 x 104 | A39759 | 1 | 30 000 | ----- | 14 000 |
| Thickwall Polypropylene | 50.0 | 357005 | 25 | 29 x 104 | A39759 | 1 | 30 000 | ----- | 14 000 |
| Open-Top Tubes | | | | | | | | | |
| Polycarbonate | 50.0 | 363647 | 25 | 29 x 104 | 356997 | 1 | 30 000 | ----- | 14 000 |
| Thickwall Polypropylene | 50.0 | 357007 | 25 | 29 x 104 | A39759 | 1 | 30 000 | ----- | 14 000 |
| Adapters for Non-Beckman Coulter Tubes and Bottles | | | | | | | | | |
| Conical Tissue Culture Tube | 175.0 | * | ----- | ----- | A39757 | 1 | ----- | ----- | ** |
| | 50.0 | * | ----- | 29 x 115 | A39760 | 1 | ----- | ----- | ** |
| | 15.0 | * | ----- | 17 x 120 | A39762 | 5 | ----- | ----- | ** |
| Round-Bottom | 100.0 | * | ----- | ----- | A39758 | 1 | ----- | ----- | ** |
| | 30.0 | * | ----- | ----- | A39763 | 2 | ----- | ----- | ** |
| | 15.0 | * | ----- | 17 x 120 | A39761 | 5 | ----- | ----- | ** |
| | 8.0/10.0 | * | ----- | ----- | A39764 | 7 | ----- | ----- | ** |
| | 5.0 | * | ----- | ----- | A39767 | 9 | ----- | ----- | ** |
| | 3.0 | * | ----- | ----- | A39769 | 10 | ----- | ----- | ** |

* Non-Beckman Coulter parts/accessories.
** Follow manufacturer's maximum speed guidelines.

Rotor Replacement Parts

- A40587 Set of Replacement O-Rings
- A39752 Lid/Tiedown Assembly

Adapters

See chart on page 2-6 for adapters used with non-Beckman Coulter tubes and bottles.



F14BCI-14x50cy

14 x 50 mL

F14BCI-14x50cy

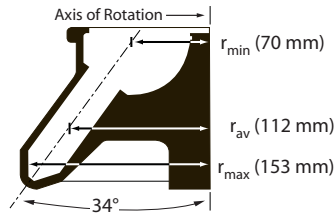

Carbon Fiber Rotor

Major applications: Large-volume for initial processing of bacteria or other cells from fermentors, clearing cell debris from homogenates, or pelleting subcellular organelles and protein precipitates.

| Max. RPM | Max. <i>g</i> | <i>k</i> Factor | Number of Tubes Volume/Size | Rotor Capacity |
|----------|---------------|-----------------|---|----------------|
| 14 000 | 33 500 | 789 | 14 x 50 mL 29 x 104 mm 1.125 x 4.0 in | 700 mL |

For use in Avanti® J Series centrifuges
(except Avanti J-HC).

No. A39754. F14BCI-14x250cy rotor.

Tubes and Bottles

| Tube Style/Material | Nominal Volume per Tube (mL) | Part No. | Quantity | Size (mm) | Required Adapters | Tubes per Adapter | <i>g</i> -Force | <i>k</i> Factor | Maximum Speed |
|---|------------------------------|----------|----------|-----------|-------------------|-------------------|-----------------|-----------------|---------------|
| Bottles with Cap Assemblies | | | | | | | | | |
| Polyallomer | 50.0 | 357001 | 6 | 29 x 104 | A39774 | 1 | 33 500 | ----- | 14 000 |
| Polycarbonate | 50.0 | 357000 | 6 | 29 x 104 | A39774 | 1 | 33 500 | ----- | 14 000 |
| Bottles with Screw Caps | | | | | | | | | |
| Polyallomer | 50.0 | 357003 | 25 | 29 x 104 | A39774 | 1 | 33 500 | ----- | 14 000 |
| Polycarbonate | 50.0 | 357002 | 25 | 29 x 104 | A39774 | 1 | 33 500 | ----- | 14 000 |
| Tubes with Snap-On Caps | | | | | | | | | |
| Polycarbonate | 50.0 | 363664 | 25 | 29 x 104 | A39774 | 1 | 33 500 | ----- | 14 000 |
| Thickwall Polypropylene | 50.0 | 357005 | 25 | 29 x 104 | A39774 | 1 | 33 500 | ----- | 14 000 |
| Open-Top Tubes | | | | | | | | | |
| Polycarbonate | 50.0 | 363647 | 25 | 29 x 104 | A39774 | 1 | 33 500 | ----- | 14 000 |
| Thickwall Polypropylene | 50.0 | 357007 | 25 | 29 x 104 | A39774 | 1 | 33 500 | ----- | 14 000 |
| Adapters for Non-Beckman Coulter Tubes and Bottles | | | | | | | | | |
| Conical Tissue Culture Tube | 50.0 | * | ----- | 29 x 115 | | | ----- | ----- | ** |
| | 15.0 | * | ----- | 17 x 120 | A39775 | 1 | ----- | ----- | ** |
| Spin Filtration Devices w/Conical Bottoms | 50.0 | * | ----- | 29 x 115 | | | ----- | ----- | ** |
| | 15.0 | * | ----- | | A39775 | 1 | ----- | ----- | ** |
| Round-Bottom | 15.0 | * | ----- | 17 x 120 | A39772 | 1 | ----- | ----- | ** |
| | 8.0/10.0 | * | ----- | | A39777 | 1 | ----- | ----- | ** |

* Non-Beckman Coulter parts/accessories.

** Follow manufacturer's maximum speed guidelines.

Rotor Replacement Parts

- A40588 Set of Replacement O-Rings
- A39755 Lid/Tiedown Assembly

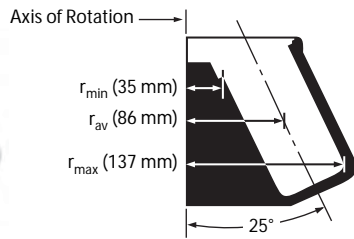

Fixed-Angle Rotor, Aluminum

Major applications: General-purpose, large-volume and multi-tube processing. Adapters permit use of up to 30 each 15-mL tubes and up to 72 each 3-mL tubes.

| Max. RPM | Max. <i>g</i> | <i>k</i> Factor | Number of Tubes Volume/Size | Rotor Capacity |
|----------|---------------|-----------------|---|----------------|
| 14 000 | 30 100 | 1 660 | 6 x 250 mL 62 x 120 mm 2.5 x 4.8 in | 1.5 L |

For use in Avanti® J Series and J2 Series centrifuges.

No. 339247. JA-14 Fixed-Angle Biosafety Rotor for 14 000 rpm operation. Tubes and bottles not included.

Tubes and Bottles

| Tube Style/Material | Nominal Volume per Tube (mL) | Part No. | Quantity | Size (mm) | Required Adapters | Tubes per Adapter | <i>g</i> -Force | <i>k</i> Factor | Maximum Speed |
|------------------------------------|------------------------------|----------|----------|-----------|-------------------|-------------------|-----------------|-----------------|---------------|
| Bottles with Screw Caps | | | | | | | | | |
| Polyallomer | 50.0 | 357003 | 25 | 29 x 104 | 356997 | 1 | 30 100 | 1 764 | 14 000 |
| Conical Polyallomer | 230.0 | 356989 | 6 | 62 x 141 | 356983 | 1 | 8 600 | 6 158 | 7 500 |
| Polycarbonate | 50.0 | 357002 | 25 | 29 x 104 | 356997 | 1 | 30 100 | 1 764 | 14 000 |
| Conical Polycarbonate | 230.0 | 356987 | 6 | 62 x 141 | 356983 | 1 | 8 600 | 6 158 | 7 500 |
| Bottles with Cap Assemblies | | | | | | | | | |
| Polyallomer | 50.0 | 357001 | 6 | 29 x 104 | 356997 | 1 | 30 100 | 1 764 | 14 000 |
| Polycarbonate | 50.0 | 357000 | 6 | 29 x 104 | 356997 | 1 | 30 100 | 1 764 | 14 000 |
| Wide-mouth Polycarbonate | 250.0 | 356013 | 6 | 62 x 120 | ----- | ----- | 30 100 | 1 764 | 14 000 |
| Wide-mouth Polypropylene | 250.0 | 356011 | 6 | 62 x 120 | ----- | ----- | 30 100 | 1 764 | 14 000 |
| Bottle with Snap-On Cap | | | | | | | | | |
| Polyallomer | 50.0 | 361694 | 24 | 29 x 104 | 356997 | 1 | 30 100 | 1 764 | 14 000 |
| Tubes with Snap-On Caps | | | | | | | | | |
| Polycarbonate | 50.0 | 363664 | 25 | 29 x 104 | 356997 | 1 | 30 100 | 1 764 | 14 000 |
| Thickwall Polypropylene | 50.0 | 357005 | 25 | 29 x 104 | 356997 | 1 | 30 100 | 1 764 | 14 000 |
| Open-Top Tubes | | | | | | | | | |
| Polycarbonate | 50.0 | 363647 | 25 | 29 x 104 | 356997 | 1 | 30 100 | 1 764 | 14 000 |
| Polypropylene | 50.0 | 357007 | 25 | 29 x 104 | 356997 | 1 | 30 100 | 1 764 | 14 000 |
| BioVials | | | | | | | | | |
| Polypropylene | 4.0 | 566353 | 1000 | 14 x 55 | 342098* | 9 | 20 000 | ----- | 14 000 |

* Can be double-stacked.

Rotor Replacement Parts

| | |
|--------|--|
| 346965 | Rotor Removal Tool |
| 870137 | Spring Pin for JA-14 Rotor Lid |
| 870138 | O-ring for Rotor Lid |
| 811656 | O-ring for Rotor Hub |
| 360473 | Rotor Lid Assembly (includes Tie-down Kit) |

Adapters

See chart on page 2-6 for adapters used with non-Beckman Coulter tubes and bottles.



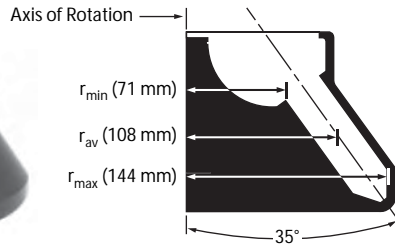

Fixed-Angle Rotor, Aluminum

Major applications: Pelleting cells, bacteria, or subcellular fractions; phase separations; binding studies.

| Max. RPM | Max. <i>g</i> | <i>k</i> Factor | Number of Tubes Volume/Size | Rotor Capacity |
|----------|---------------|-----------------|--|----------------|
| 12 000* | 23 200 | 1 244 | 12 x 50 mL 30 x 103 mm (conical) 1.17 x 4 in | 600 mL |

For use in Avanti® J Series and J2 Series centrifuges.

No. 360992. JA-12 Fixed-Angle Rotor with Dual-locking Biosafety Lid for 12 000 rpm operation. Tubes and bottles not included.

No. 360993. JA-12 Fixed-Angle Rotor with Single-locking Lid for 12 000 rpm operation. Tubes and bottles not included.

Tubes and Bottles

| Tube Style/Material | Nominal Volume per Tube (mL) | Part No. | Quantity | Size (mm) | Required Adapters | Tubes per Adapter | <i>g</i> -Force | <i>k</i> Factor | Maximum Speed |
|---------------------|------------------------------|----------|----------|-----------|-------------------|-------------------|-----------------|-----------------|---------------|
| Conical* | 50.0 | — | — | — | — | — | 23 200 | — | 12 000 |

* Tested using Corning and Falcon 50-mL conical tubes. Corning is a registered trademark of Corning Class Works; Falcon is a registered trademark of Becton, Dickinson and Company.
See chart on page 2-6 for adapters used with non-Beckman Coulter tubes and bottles.

Rotor Replacement Parts

- 364846 Dual-locking Lid Assembly
- 360991 Single-locking Lid Assembly
- 360999 Tie-down Bolt (for use without lid)
- 961696 O-ring for Rotor Lids
- 961697 O-ring for Rotor Body
- 364919 Tie-down Kit (Single)
- 364922 Tie-down Kit (Dual-locking)
- 360998 Rotor Removal Tool

Rotor Supplies

- 339558 Rotor Cleaning Kit
- 339555 Solution 555™ (1 qt.)
- 335148 Silicone vacuum grease (2 oz.)
- 306812 Spinkote™ Lubricant (1 oz.)

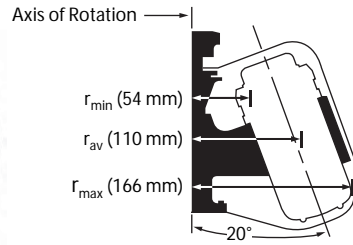

Fixed-Angle Rotor, Aluminum

Major applications: Large-volume for initial processing of bacteria or other cells from fermentors, clearing cell debris from homogenates, or pelleting subcellular organelles and protein precipitates.

| Max. RPM | Max. <i>g</i> | <i>k</i> Factor | Number of Tubes Volume/Size | Rotor Capacity |
|----------|---------------|-----------------|--|----------------|
| 10 000 | 18 600 | 2 840 | 6 x 500 mL 69 x 160 mm 2.75 x 6.5 in | 3 L |

For use in Avanti® J Series and J2 Series centrifuges.

No. 369681. J-Lite® JLA-10.500 Rotor Assembly. Includes 6 cannisters with secondary Biosafety liquid closures.

No. 360828. Biosafety Cannisters for JLA-10.500 (set of 2 with 2 secondary liquid closures).

Tubes and Bottles

| Tube Style/Material | Nominal Volume per Tube (mL) | Part No. | Quantity | Size (mm) | Required Adapters | Tubes per Adapter | <i>g</i> -Force | <i>k</i> Factor | Maximum Speed |
|------------------------------------|------------------------------|----------|----------|-----------|-------------------|-------------------|-----------------|-----------------|---------------|
| Bottles with Cap Assemblies | | | | | | | | | |
| Polyallomer | 50.0 | 357001 | 6 | 29 x 104 | 356996 | 1 | 12 000 | 2 840 | 10 000 |
| Polycarbonate | 50.0 | 357000 | 6 | 29 x 104 | 356996 | 1 | 12 000 | 2 840 | 10 000 |
| | 500.0 | 361690 | 6 | 62 x 160 | ----- | ----- | 18 600 | 2 840 | 10 000 |
| Wide-mouth Polycarbonate | 250.0 | 356013 | 6 | 62 x 122 | 362750 | 1 | 17 700 | 2 840 | 10 000 |
| Polypropylene | 500.0 | 361691 | 6 | 62 x 160 | ----- | ----- | 11 900 | 4 440 | 8 000 |
| Wide-mouth Polypropylene | 250.0 | 356011 | 6 | 62 x 122 | 362750 | 1 | 17 700 | 2 840 | 10 000 |
| Bottles with Screw Caps | | | | | | | | | |
| Polyallomer | 50.0 | 357003 | 25 | 29 x 104 | 356996 | 1 | 12 000 | 2 840 | 10 000 |
| Polycarbonate | 50.0 | 357002 | 25 | 29 x 104 | 356996 | 1 | 12 000 | 2 840 | 10 000 |
| Tubes with Snap-On Caps | | | | | | | | | |
| Polypropylene | 50.0 | 357005 | 25 | 29 x 104 | 356996 | 1 | 12 000 | 2 840 | 10 000 |
| Polycarbonate | 50.0 | 363664 | 25 | 29 x 104 | 356996 | 1 | 12 000 | 2 840 | 10 000 |
| Open-Top Tubes | | | | | | | | | |
| Polycarbonate | 50.0 | 363647 | 25 | 29 x 104 | 356996 | 1 | 12 000 | 2 840 | 10 000 |
| Polypropylene | 50.0 | 357007 | 25 | 29 x 104 | 356996 | 1 | 12 000 | 2 840 | 10 000 |
| BioVials | | | | | | | | | |
| Polypropylene | 4.0 | 566353 | 1000 | 14 x 55 | 362750/342098* | 9 | ----- | ----- | 10 000 |

* BioVials require adapters P/N 362750 AND 342098 to run in the JLA-10.500. Two adapters P/N 342098 can be double-stacked inside of one adapter P/N 362750 per rotor cavity if greater capacity is desired.

Rotor Replacement Parts

- 363334 Rotor Lid Assembly
- 360828 Cannisters (set of 2 with 2 cannister closures)
- 360842 Cannister Closure Assembly (1)
- 360848 O-ring for Cannister Closure (set of 12)
- 363335 Cannister Rack
- 360834 Cannister Sleeve Washer

Adapters

See chart on page 2–6 for adapters used with non-Beckman Coulter tubes and bottles.



F10BCI-6x500y

6 x 500 mL

F10BCI-6x500y

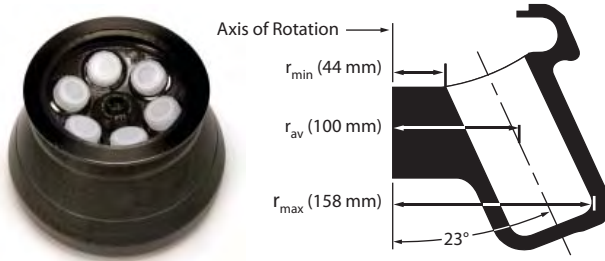

Carbon Fiber Rotor

Major applications: Large-volume for initial processing of bacteria or other cells from fermentors, clearing cell debris from homogenates, or pelleting subcellular organelles and protein precipitates.

| Max. RPM | Max. <i>g</i> | <i>k</i> Factor | Number of Tubes Volume/Size | Rotor Capacity |
|----------|---------------|-----------------|--|----------------|
| 10 000 | 17 700 | 3 417 | 6 x 500 mL 69 x 160 mm 2.75 x 6.5 in | 3 L |

For use in Avanti® J Series centrifuges
(except Avanti J-HC).

No. 393033. F10BCI-6x500y rotor.

Tubes and Bottles

| Tube Style/Material | Nominal Volume per Tube (mL) | Part No. | Quantity | Size (mm) | Required Adapters | Tubes per Adapter | <i>g</i> -Force | <i>k</i> Factor | Maximum Speed |
|---|------------------------------|----------|----------|-----------|-------------------|-------------------|-----------------|-----------------|---------------|
| Bottles with Cap Assemblies | | | | | | | | | |
| Polyallomer | 50.0 | 357001 | 6 | 29 x 104 | 356996 | 1 | 17 700 | ----- | 10 000 |
| Polycarbonate | 50.0 | 357000 | 6 | 29 x 104 | 356996 | 1 | 17 700 | ----- | 10 000 |
| Wide-mouth Polycarbonate | 250.0 | 356013 | 6 | 62 x 120 | 362750 | 1 | 17 700 | ----- | 10 000 |
| | 500.0 | 355605 | 6 | 69 x 160 | ----- | ----- | 17 700 | 3 610 | 10 000 |
| Polypropylene | 500.0 | 361691 | 6 | 69 x 159 | ----- | ----- | 11 300 | ----- | 8 000 |
| Wide-mouth Polypropylene | 250.0 | 356011 | 6 | 62 x 120 | 362750 | 1 | 17 700 | ----- | 10 000 |
| Bottles with Screw Caps | | | | | | | | | |
| Polyallomer | 50.0 | 357003 | 25 | 29 x 104 | 356996 | 1 | 17 700 | ----- | 10 000 |
| Polycarbonate | 50.0 | 357002 | 25 | 29 x 104 | 356996 | 1 | 17 700 | ----- | 10 000 |
| Tubes with Snap-On Caps | | | | | | | | | |
| Polycarbonate | 50.0 | 363664 | 25 | 29 x 104 | 356996 | 1 | 17 700 | ----- | 10 000 |
| Thickwall Polypropylene | 50.0 | 357005 | 25 | 29 x 104 | 356996 | 1 | 17 700 | ----- | 10 000 |
| Open-Top Tubes | | | | | | | | | |
| Polycarbonate | 50.0 | 363647 | 25 | 29 x 104 | 356996 | 1 | 17 700 | ----- | 10 000 |
| Thickwall Polypropylene | 50.0 | 357007 | 25 | 29 x 104 | 356996 | 1 | 17 700 | ----- | 10 000 |
| Adapters for Non-Beckman Coulter Tubes and Bottles | | | | | | | | | |
| Conical Tissue Culture Tube | 50.0 | * | ----- | 29 x 115 | 356965 | 1 | ----- | ----- | ** |
| | 15.0 | * | ----- | 17 x 120 | 356960 | 5 | ----- | ----- | ** |
| Round-Bottom | 13.0 | * | ----- | 17 x 120 | 356994 | 5 | ----- | ----- | ** |
| | 7.0 | * | ----- | 13 x 100 | 356973 | 9 | ----- | ----- | ** |
| | 4.0 | * | ----- | 12 x 75 | 356967 | 11 | ----- | ----- | * |

* Non-Beckman Coulter parts/accessories.

** Follow manufacturer's maximum speed guidelines.

Rotor Replacement Parts

- 393032 Set of Replacement O-Rings
- 393031 Lid/Tiedown Assembly

Adapters

See chart on page 2-6 for adapters used with non-Beckman Coulter tubes and bottles.



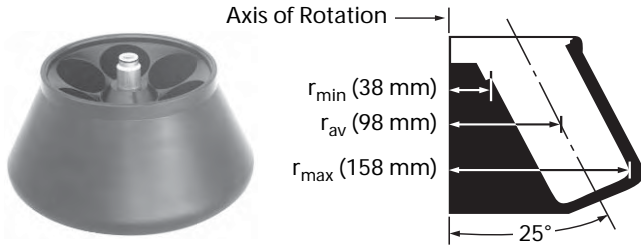

Fixed-Angle Rotor, Aluminum

Major applications: Large-volume for initial processing of tissue homogenates and other large particles.

| Max. RPM | Max. <i>g</i> | <i>k</i> Factor | Number of Tubes Volume/Size | Rotor Capacity |
|----------|---------------|-----------------|--|----------------|
| 10 000 | 17 700 | 3 610 | 6 x 500 mL 69 x 160 mm 2.75 x 6.5 in | 3 L |

For use in Avanti® J Series centrifuges.

No. 369687. JA-10 Fixed-Angle Rotor for 10 000 rpm operation. Includes carrying handle. Tubes and bottles not included.

Tubes and Bottles

| Tube Style/Material | Nominal Volume per Tube (mL) | Part No. | Quantity | Size (mm) | Required Adapters | Tubes per Adapter | <i>g</i> -Force | <i>k</i> Factor | Maximum Speed |
|------------------------------------|------------------------------|----------|----------|-----------|-------------------|-------------------|-----------------|-----------------|---------------|
| Bottles with Cap Assemblies | | | | | | | | | |
| Polyallomer | 50.0 | 357001 | 6 | 29 x 104 | 356996 | 1 | 17 700 | ----- | 10 000 |
| Polycarbonate | 50.0 | 357000 | 6 | 29 x 104 | 356996 | 1 | 17 700 | ----- | 10 000 |
| Wide-mouth Polycarbonate | 250.0 | 356013 | 6 | 62 x 120 | 362750 | 1 | 17 700 | ----- | 10 000 |
| | 500.0 | 355605 | 6 | 62 x 160 | ----- | ----- | 17 700 | 3 610 | 10 000 |
| Wide-mouth Polypropylene | 250.0 | 356011 | 6 | 62 x 120 | 362750 | 1 | 17 700 | ----- | 10 000 |
| | 500.0 | 355607 | 6 | 62 x 160 | ----- | ----- | 11 300 | ----- | 8 000 |
| Bottles with Screw Caps | | | | | | | | | |
| Polyallomer | 50.0 | 357003 | 25 | 29 x 104 | 356996 | 1 | 17 700 | ----- | 10 000 |
| Tubes with Snap-On Caps | | | | | | | | | |
| Polycarbonate | 50.0 | 363664 | 25 | 29 x 104 | 356996 | 1 | 17 700 | ----- | 10 000 |
| Thickwall Polypropylene | 50.0 | 357005 | 25 | 29 x 104 | 356996 | 1 | 17 700 | ----- | 10 000 |
| Open-Top Tubes | | | | | | | | | |
| Polycarbonate | 50.0 | 363647 | 25 | 29 x 104 | 356996 | 1 | 17 700 | ----- | 10 000 |
| Thickwall Polypropylene | 50.0 | 357007 | 25 | 29 x 104 | 356996 | 1 | 17 700 | ----- | 10 000 |
| BioVials | | | | | | | | | |
| Polypropylene | 4.0 | 566353 | 1000 | 14 x 55 | 362750/342098* | 9 | 17 700 | ----- | 10 000 |

* BioVials require adapters P/N 362750 AND 342098 to run in the JA-10. Two adapters P/N 342098 can be double-stacked inside of one adapter P/N 362750 per rotor cavity if greater capacity is desired.

Rotor Replacement Parts

- 334827 Rotor Removal Tool
- 870139 O-ring for Rotor Lid
- 870980 O-ring for Rotor Body
- 364911 Tie-down Kit
- 334492 Rotor Lid

Adapters

See chart on page 2-6 for adapters used with non-Beckman Coulter tubes and bottles.



JLA-9.1000

4 x 1000 mL

JLA-9.1000



Fixed-Angle Rotor, Aluminum

Major applications: General purpose, large-volume processing, pelleting of bacteria, subcellular organelles, viruses, and precipitates. Empty rotor weight is 23.9 lb (10.8 kg).

| Max. RPM | Max. g | k Factor | Number of Tubes Volume/Size | Rotor Capacity |
|----------|--------|----------|--|----------------|
| 9 000 | 16 800 | 2 540 | 4 x 1000 mL 95 x 191 mm 3.8 x 7.65 in. | 4 L |

For use in Avanti® J Series centrifuges.

No. 366754. J-Lite® JLA-9.1000 Rotor Package. Includes rotor body, lid, carbon fiber cannisters, and labware kit 392574.

No. 969330. J-Lite JLA-9.1000 Rotor Package. Includes rotor body, lid, carbon fiber cannisters, labware kit 392574, and 4 polycarbonate bottles with cap assemblies (two 363676).

No. 969331. J-Lite JLA-9.1000 Rotor Package. Includes rotor body, lid, carbon fiber cannisters, labware kit 392574, and 4 polypropylene bottles with cap assemblies (two 363678).

Tubes and Bottles

| Tube Style/Material | Nominal Volume per Tube (mL) | Part No. | Quantity | Size (mm) | Required Adapters | Tubes per Adapter | g-Force | k Factor | Maximum Speed* |
|-------------------------------------|------------------------------|----------|----------|-----------|--------------------|-------------------|---------|----------|----------------|
| Bottles with Cap Assemblies® | | | | | | | | | |
| J-Lite PC-1000† (Polycarbonate) | 1000.0 | 363676 | 2 | 95 x 191 | ----- | ----- | 16 800 | 2 540 | 9 000 |
| J-Lite PP-1000‡ (Polypropylene) | 1000.0 | 363678 | 2 | 95 x 191 | ----- | ----- | 13 300 | 3 220 | 8 000 |
| Polyallomer | 50.0 | 357001 | 6 | 29 x 104 | 356996 in 363683** | 1 | ----- | ----- | 9 000 |
| Polycarbonate | 50.0 | 357000 | 6 | 29 x 104 | 356996 in 363683** | 1 | ----- | ----- | 9 000 |
| Wide-mouth Polycarbonate | 250.0 | 356013 | 6 | 62 x 120 | 362750 in 363683** | 1 | ----- | ----- | 9 000 |
| | 500.0 | 355605 | 6 | 69 x 160 | 363683 | 1 | ----- | ----- | 9 000 |
| Wide-mouth Polypropylene | 250.0 | 356011 | 6 | 62 x 120 | 362750 in 363683** | 1 | ----- | ----- | 9 000 |
| | 500.0 | 355607 | 6 | 69 x 160 | 363683 | 1 | ----- | ----- | 8 000 |
| Bottles Only | | | | | | | | | |
| J-Lite PC-1000 (Polycarbonate) | 1000.0 | 366751 | 2 | 95 x 191 | ----- | ----- | 16 800 | 2 540 | 9 000 |
| J-Lite PP-1000 (Polypropylene) | 1000.0 | 366752 | 2 | 95 x 191 | ----- | ----- | 13 300 | 3 220 | 8 000 |
| Bottles with Screw Caps | | | | | | | | | |
| Polyallomer | 50.0 | 357003 | 25 | 29 x 104 | 356996 in 363683** | 1 | ----- | ----- | 9 000 |
| Tubes with Snap-On Caps | | | | | | | | | |
| Polycarbonate | 50.0 | 363664 | 25 | 29 x 104 | 356996 in 363683** | 1 | ----- | ----- | 9 000 |
| Thickwall Polypropylene | 50.0 | 357005 | 25 | 29 x 104 | 356996 in 363683** | 1 | ----- | ----- | 9 000 |

* Bottle assemblies include cap/closure. The cap/closure serves the dual purpose of sealing the bottle and providing a secondary seal on the carbon-fiber cannister to minimize sample loss resulting from bottle leak or failure.

† PC-1000 must be run with cap/closure; minimum fill volume is 500 mL.

‡ PP-1000 must be run with cap/closure; minimum fill volume is 1 000 mL.

** These adapters fit inside one another to accommodate smaller bottles and tubes.

Adapters

See chart on page 2–6 for adapters used with non-Beckman Coulter tubes and bottles.



Tubes and Bottles

| Tube Style/Material | Nominal Volume per Tube (mL) | Part No. | Quantity | Size (mm) | Required Adapters | Tubes per Adapter | g-Force | k Factor | Maximum Speed* |
|-------------------------|------------------------------|----------|----------|-----------|-------------------|-------------------|---------|----------|----------------|
| Open-Top Tubes | | | | | | | | | |
| Polycarbonate | 50.0 | 363647 | 25 | 29 x 104 | 356996 in 363683 | 1 | ----- | ----- | 9 000 |
| Thickwall Polypropylene | 50.0 | 357007 | 25 | 29 x 104 | 356996 in 363683 | 1 | ----- | ----- | 9 000 |

Labware Kit Part Number 392574

- Includes: 1 ea. 974627 Bottle Rack (holds 6 bottles)
1 ea. 363646 Spatula
1 ea. 366770 Tool Kit

Accessories

- 974627 Bottle Rack (holds 6 bottles for easy transport)
363663 Bottle Rack (holds 3 bottles for easy transport)
363683 500-mL Bottle Adapter
363646 Spatula
363689 Vent Plug Screw and O-ring (pkg. of 6)
363680 Cap/Closure Assembly (set of 2)
(Includes cap/closure, O-ring, plug, and plug O-ring)
366748 Plug Assembly, AutoVent Polycarbonate (pkg. of 2)
366749 Plug Assembly, AutoVent Ultem¹ (pkg. of 2)
366770 Tool Kit (includes one bottle grip and one wrench)
366772 Teflon Spray

Rotor Replacement Parts

- 363583 Rotor Lid Assembly
363686 J-Lite 1000 Removable Cannisters (set of 2)
970884 O-ring, Cap/Closure
970883 O-ring, Plug
363601 Cannister Sleeve Washer (set of 6)
366768 Cap/Closure Replacement Assembly (set of 6)
366769 Cap/Closure Replacement O-rings (set of 6)
366767 AutoVent Plug Replacement O-rings (set of 6)
Includes six large plug O-rings and six AutoVent plug O-rings.

Adapters

See chart on page 2-6 for adapters used with non-Beckman Coulter tubes and bottles.

356996



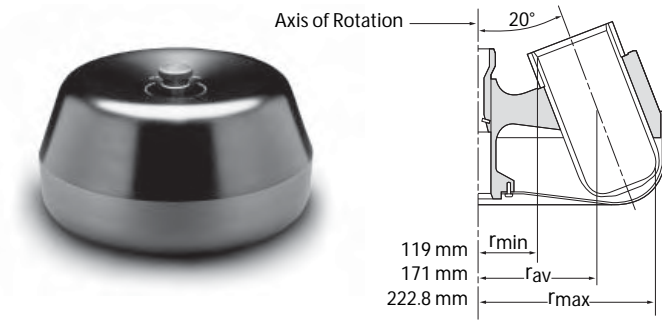

Fixed-Angle Rotor, Aluminum

Major applications: General purpose, large-volume processing, pelleting of bacteria, cell organelles, viruses, and precipitates. Empty rotor weight is 16.8 kg (37 lb).

| Max. RPM | Max. g | k Factor | Number of Bottles Volume/Size | Rotor Capacity |
|----------|--------|----------|--|----------------|
| 8 000 | 15 970 | 2 482 | 6 x 1000 mL 95 x 191 mm 3.8 x 7.65 in. | 6 L |

For use in Avanti® J-26 XP Series centrifuges.

No. 363688. J-Lite® JLA-8.1000 Rotor Package . Includes rotor body, Biosafety lid, carbon fiber cannisters, and labware kit 392574.

No. 969328. J-Lite JLA-8.1000 Rotor Package. Includes rotor body, lid, carbon fiber cannisters, labware kit 392574, and 6 polycarbonate bottles with cap assemblies (three 363676).

No. 969329. J-Lite JLA-8.1000 Rotor Package. Includes rotor body, lid, carbon fiber cannisters, labware kit 392574, and 6 polypropylene bottles with cap assemblies (three 363678).

Tubes and Bottles

| Tube Style/Material | Nominal Volume per Tube (mL) | Part No. | Quantity | Size (mm) | Required Adapters | Tubes per Adapter | g-Force | k Factor | Maximum Speed |
|-------------------------------------|------------------------------|----------|----------|-----------|--------------------|-------------------|---------|----------|---------------|
| Bottles with Cap Assemblies* | | | | | | | | | |
| J-Lite PC-1000† (Polycarbonate) | 1000.0 | 363676 | 2 | 95 x 191 | ----- | ----- | 15 900 | 2 500 | 8 000 |
| J-Lite PP-1000‡ (Polypropylene) | 1000.0 | 363678 | 2 | 95 x 191 | ----- | ----- | 12 200 | 2 845 | 7 000 |
| Polyallomer | 50.0 | 357001 | 6 | 29 x 104 | 356996 in 363683** | 1 | ----- | ----- | 8 000 |
| Polycarbonate | 50.0 | 357000 | 6 | 29 x 104 | 356996 in 363683** | 1 | ----- | ----- | 8 000 |
| Wide-mouth Polycarbonate | 250.0 | 356013 | 6 | 62 x 120 | 362750 in 363683** | 1 | ----- | ----- | 8 000 |
| | 500.0 | 355605 | 6 | 69 x 160 | 363683 | 1 | ----- | ----- | 8 000 |
| Wide-mouth Polypropylene | 250.0 | 356011 | 6 | 62 x 120 | 362750 in 363683** | 1 | ----- | ----- | 8 000 |
| | 500.0 | 355607 | 6 | 69 x 160 | 363683 | 1 | ----- | ----- | 8 000 |
| Bottles Only | | | | | | | | | |
| J-Lite PC-1000 (Polycarbonate) | 1000.0 | 366751 | 2 | 95 x 191 | ----- | ----- | 15 970 | 2 470 | 8 000 |
| J-Lite PP-1000 (Polypropylene) | 1000.0 | 366752 | 2 | 95 x 191 | ----- | ----- | 12 227 | 3 242 | 7 000 |
| Bottles with Screw Caps | | | | | | | | | |
| Polyallomer | 50.0 | 357003 | 25 | 29 x 104 | 356996 in 363683** | 1 | ----- | ----- | 8 000 |
| Tubes with Snap-On Caps | | | | | | | | | |
| Polycarbonate | 50.0 | 363664 | 25 | 29 x 104 | 356996 in 363683** | 1 | ----- | ----- | 8 000 |
| Thickwall Polypropylene | 50.0 | 357005 | 25 | 29 x 104 | 356996 in 363683** | 1 | ----- | ----- | 8 000 |

* Bottle assemblies include cap/closure. The cap/closure serves the dual purpose of sealing the bottle and providing a secondary seal on the carbon-fiber cannister to minimize sample loss resulting from bottle leak or failure.

† PC-1000 must be run with cap/closure; minimum fill volume is 500 mL.

‡ PP-1000 must be run with cap/closure; minimum fill volume is 1 000 mL.

** These adapters fit inside one another to accommodate smaller bottles and tubes.

Adapters

See chart on page 2–6 for adapters used with non-Beckman Coulter tubes and bottles.



Tubes and Bottles

| Tube Style/Material | Nominal Volume per Tube (mL) | Part No. | Quantity | Size (mm) | Required Adapters | Tubes per Adapter | g-Force | k Factor | Maximum Speed |
|-------------------------|------------------------------|----------|----------|-----------|-------------------|-------------------|---------|----------|---------------|
| Open-Top Tubes | | | | | | | | | |
| Polycarbonate | 50.0 | 363647 | 25 | 29 x 104 | 356996 in 363683 | 1 | ----- | ----- | 8 000 |
| Thickwall Polypropylene | 50.0 | 357007 | 25 | 29 x 104 | 356996 in 363683 | 1 | ----- | ----- | 8 000 |

Labware Kit Part Number 392574

Includes: 1 ea. 974627 Bottle Rack (holds 6 bottles)
1 ea. 363646 Spatula
1 ea. 366770 Tool Kit

Accessories

974627 Bottle Rack (holds 6 bottles for easy transport)
363663 Bottle Rack (holds 3 bottles for easy transport)
363683 500-mL Bottle Adapter
363646 Spatula
363689 Vent Plug Screw and O-ring (pkg. of 6)
363680 Cap/Closure Assembly (set of 2)
(Includes cap/closure, O-ring, plug, and plug O-ring)
366748 Plug Assembly, AutoVent Polycarbonate (pkg. of 2)
366749 Plug Assembly, AutoVent Ultem (pkg. of 2)
366770 Tool Kit (includes one bottle grip and one wrench)
366772 Teflon Spray

Rotor Replacement Parts

363563 Rotor Lid Assembly
363686 J-Lite Removable Cannisters (set of 2)
970884 O-ring, Cap/Closure
970883 O-ring, Plug
363601 Cannister Sleeve Washer (set of 6)
366768 Cap/Closure Replacement Assembly (set of 6)
366769 Cap/Closure Replacement O-rings (set of 6)
366767 AutoVent Plug Replacement O-rings (set of 6)
Includes six large plug O-rings and six AutoVent plug O-rings.

Adapters

See chart on page 2-6 for adapters used with non-Beckman Coulter tubes and bottles.

356996



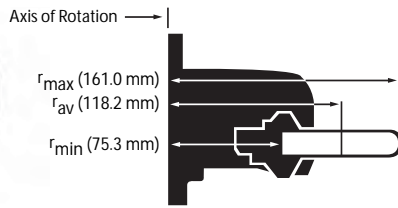

Swinging-Bucket Rotor, Aluminum, Titanium Buckets

Major applications: Harvesting bacteria, processing tissue homogenates, subcellular particulates, routine pelleting such as precipitates and phase separations.

| Max. RPM | Max. <i>g</i> | <i>k</i> Factor | Number of Tubes Volume/Size | Rotor Capacity |
|----------|---------------|-----------------|---|----------------|
| 24 000* | 103 900 | 334 | 6 x 38.5 mL 25 x 89 mm 1 x 3.5 in | 231 mL |

For use in Avanti® J Series centrifuges
(except Avanti J-E).

No. 360743. JS-24.38 Swinging-Bucket Rotor, with six 38.5-mL buckets.

Tubes and Bottles

| Tube Style/Material | Nominal Volume per Tube (mL) | Part No. | Quantity | Size (mm) | Required Adapters | Tubes per Adapter | <i>g</i> -Force | <i>k</i> Factor | Maximum Speed* |
|-----------------------------------|------------------------------|----------|----------|-----------|-------------------|-------------------|-----------------|-----------------|----------------|
| Quick-Seal® Bell-Top Tubes | | | | | | | | | |
| Polyallomer | 15.0 | 343664 | 50 | 25 x 38 | 355536† | 1 | 103 900 | 167 | 24 000 |
| | 27.0 | 343665 | 50 | 25 x 64 | 355536† | 1 | 103 900 | 260 | 24 000 |
| | 33.0 | 344623 | 50 | 25 x 83 | 355536† | 1 | 103 900 | 317 | 24 000 |
| konical Polyallomer | 8.5 | 358652 | 50 | 25 x 38 | 358155 | 1 | 103 900 | 167 | 24 000 |
| | 23.0 | 358654 | 50 | 25 x 76 | 355536† | 1 | 103 900 | 297 | 24 000 |
| | | | | | 358155 | | | | |
| 355536† | | | | | | | | | |
| | Open-Top Tubes | | | | | | | | |
| Polyallomer | 38.5 | 326823 | 50 | 25 x 89 | --- | --- | 103 900 | 334 | 24 000 |
| konical™ Polyallomer | 25.0 | 358125 | 50 | 25 x 76 | 358156 | 1 | 95 500 | 297 | 24 000 |
| | 30.0 | 358126 | 50 | 25 x 89 | 358156 | 1 | 103 900 | 334 | 24 000 |
| Thickwall Polyallomer | 32.0 | 355642 | 25 | 25 x 89 | --- | --- | 103 900 | 334 | 24 000 |
| Thickwall Polycarbonate | 32.0 | 355631 | 25 | 25 x 89 | --- | --- | 103 900 | 334 | 24 000 |
| Ultra-Clear™ | 38.5 | 344058 | 50 | 25 x 89 | --- | --- | 103 900 | 334 | 24 000 |

* Reaches 24 000 rpm in the Avanti J-30I centrifuge only. Not recommended for use in Avanti J-25 Series (max. speed 10 000 rpm), or Avanti J-26 XP Series (max. speed 10 000 rpm). Incompatible with all J2 Series.

† Noryl Floating Spacer. Noryl is a registered trademark of GE Plastics.

Rotor Replacement Parts

| | |
|--------|---|
| 362397 | Bucket Set - 38 mL (set of 6 with caps and O-rings) |
| 812715 | Bucket O-ring |
| 362785 | Rotor Stand |

Adapters

See chart on page 2-6 for adapters used with non-Beckman Coulter tubes and bottles.



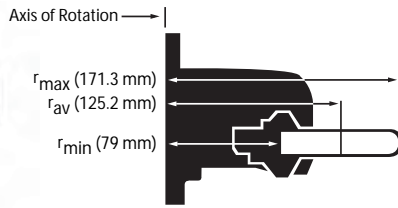

Swinging-Bucket Rotor, Aluminum, Titanium Buckets

Major applications: Harvesting bacteria, processing tissue homogenates, subcellular particulates, routine pelleting such as precipitates and phase separations.

| Max. RPM | Max. <i>g</i> | <i>k</i> Factor | Number of Tubes Volume/Size | Rotor Capacity |
|----------|---------------|-----------------|--|----------------|
| 24 000* | 110 500 | 376 | 6 x 15 mL 16 x 96 mm 0.625 x 3.75 in | 90 mL |

For use in Avanti® J Series centrifuges (except Avanti J-E).

No. 362396. JS-24.15 Swinging-Bucket Rotor with six 15-mL buckets.

Tubes and Bottles

| Tube Style/Material | Nominal Volume per Tube (mL) | Part No. | Quantity | Size (mm) | Required Adapters | Tubes per Adapter | <i>g</i> -Force | <i>k</i> Factor | Maximum Speed* |
|-----------------------------------|------------------------------|----------|----------|-----------|-------------------|-------------------|-----------------|-----------------|----------------|
| Quick-Seal® Bell-Top Tubes | | | | | | | | | |
| Polyallomer | 4.2 | 356562 | 50 | 16 x 38 | 355579† | 1 | 110 500 | 193 | 24 000 |
| | 6.3 | 345830 | 50 | 16 x 45 | 355579† | 1 | 110 500 | 215 | 24 000 |
| | 8.0 | 344621 | 50 | 16 x 58 | 355579† | 1 | 110 500 | 261 | 24 000 |
| | 10.0 | 344622 | 50 | 16 x 67 | 355579† | 1 | 110 500 | 293 | 24 000 |
| Open-Top Tubes | | | | | | | | | |
| Polyallomer | 15.0 | 361707 | 50 | 16 x 96 | --- | --- | 110 500 | 376 | 24 000 |
| Konical Polyallomer | 12.5 | 361708 | 50 | 16 x 93 | 358155 | 1 | 108 500 | 368 | 24 000 |
| Ultra-Clear™ | 15.0 | 361706 | 50 | 16 x 96 | --- | --- | 110 500 | 376 | 24 000 |

* Reaches 24 000 rpm in the Avanti J-301 centrifuge only. Not recommended for use in Avanti J-25 Series (max speed 10 000 rpm), or Avanti J-26 XP Series (max. speed 10 000 rpm). Incompatible with all J2 Series.

† Noryl Floating Spacer. Noryl is a registered trademark of GE Plastics.

Rotor Replacement Parts

| | |
|--------|---|
| 362398 | Bucket Set - 15 mL (set of 6 with caps and O-rings) |
| 815472 | Bucket O-ring |
| 362785 | Rotor Stand |
| 364802 | Rotor and Adapter Assembly |

Adapters

See chart on page 2–6 for adapters used with non-Beckman Coulter tubes and bottles.



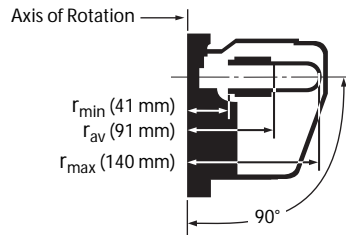

Swinging-Bucket Rotor, Aluminum

Major applications: Harvesting bacteria, processing tissue homogenates, separating cell particulates. Isolation of cell membrane using density gradients.

| Max. RPM | Max. <i>g</i> | <i>k</i> Factor | Number of Tubes Volume/Size | Rotor Capacity |
|----------|---------------|-----------------|--|----------------|
| 13 000 | 26 500 | 1 841 | 6 x 50 mL 29 x 105 mm 1.125 x 4 in | 300 mL |

For use in Avanti® J Series and J2 Series centrifuges.

No. 346963. JS-13.1 Swinging-Bucket Rotor for 13 000 rpm operation. Includes carrying handle. Tubes and bottles not included.

Tubes and Bottles

| Tube Style/Material | Nominal Volume per Tube (mL) | Part No. | Quantity | Size (mm) | Required Adapters | Tubes per Adapter | <i>g</i> -Force | <i>k</i> Factor | Maximum Speed |
|--------------------------------|------------------------------|----------|----------|-----------|-------------------|-------------------|-----------------|-----------------|---------------|
| Bottles with Screw Caps | | | | | | | | | |
| Polyallomer | 50.0 | 357003 | 25 | 29 x 104 | ----- | ----- | 26 500 | 1 840 | 13 000 |
| Polycarbonate | 10.0 | 355672 | 25 | 16 x 80 | 342327/870329 | 1 | 26 500 | 1 840 | 13 000 |
| | 50.0 | 357002 | 25 | 29 x 104 | ----- | ----- | 26 500 | 1 840 | 13 000 |
| Tubes with Snap-On Caps | | | | | | | | | |
| Polypropylene | 50.0 | 357005† | 25 | 29 x 104 | ----- | ----- | 26 500 | 1 840 | 13 000 |
| Polycarbonate | 50.0 | 363664† | 25 | 29 x 104 | ----- | ----- | 26 500 | 1 840 | 13 000 |
| Polyethylene | 1.8 | 340196 | 500 | 11 x 39 | 344497* | 3 | 26 500 | 1 840 | 13 000 |
| Polyallomer | Natural | 1.5 | 357448 | 500 | 11 x 38 | 344497* | 3 | 26 500 | 1 840 |
| Polypropylene | Orange | 1.5 | 356094 | 500 | 11 x 38 | 344497* | 3 | 26 500 | 1 840 |
| | Yellow | 1.5 | 356093 | 500 | 11 x 38 | 344497* | 3 | 26 500 | 1 840 |
| | Green | 1.5 | 356092 | 500 | 11 x 38 | 344497* | 3 | 26 500 | 1 840 |
| | Blue | 1.5 | 356091 | 500 | 11 x 38 | 344497* | 3 | 26 500 | 1 840 |
| | Natural | 1.5 | 356090 | 500 | 11 x 38 | 344497* | 3 | 26 500 | 1 840 |
| Open-Top Tubes | | | | | | | | | |
| Polycarbonate | 10.0 | 355630 | 25 | 16 x 76 | 342327/870329 | 4/1 | 8 000 | ----- | 13 000 |

* Can be double-stacked. Force will vary depending on tube position.
† Cannot be run with caps in this rotor.

Rotor Replacement Parts

- 346965 Rotor Removal Tool
- 346976 Buckets (set of 6)
- 364862 Rotor Tie-down Assembly
- 364921 Tie-down Kit
- 346979 Windshield Bowl Trim
- 346964 Rotor Lid Assembly

Adapters

See chart on page 2-6 for adapters used with non-Beckman Coulter tubes and bottles.

342327 344497 870329



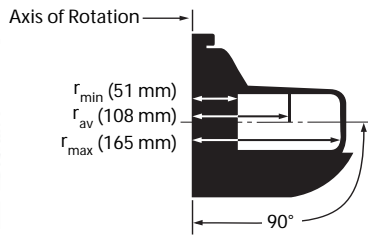

Swinging-Bucket Rotor, Aluminum

Major applications: Initial processing of cells and removal of cell debris from culture media.

| Max. RPM | Max. <i>g</i> | <i>k</i> Factor | Number of Tubes Volume/Size | Rotor Capacity |
|----------|---------------|-----------------|---|----------------|
| 7 500 | 10 400 | 5 287 | 4 x 250 mL 62 x 136 mm 2.5 x 5.5 in | 1 L |

For use in Avanti® J Series centrifuges (except Avanti J-E) and J2 Series centrifuges.

No. 336380. JS-7.5 Swinging-Bucket Rotor for 7 500 rpm operation. Includes four 250-mL buckets. Multitube carriers available separately. Tubes and bottles not included.
No. 362212. JS-7.5 Rotor without buckets.

Multitube Carriers

For added versatility, three Multitube Carriers are available for the JS-7.5 Rotor. These Carriers require no adapters to accommodate 50-mL conical tubes, 50-mL round-bottom tubes, and 5-mL round-bottom tubes. Multitube carriers are interchangeable with the buckets of the JS-7.5 Rotor.

50-mL Conical Tube Carrier

No. 362213. Multitube Carrier for 50-mL conical tubes. Holds three tubes per carrier for maximum rotor capacity of 12 x 50-mL conical tubes. Set of two.



Major applications: General-purpose pelleting (especially of cells), as well as nucleic acid precipitations and isolation of mononuclear cells using Ficoll-Paque.*

| Max. RPM | Max. <i>g</i> | <i>k</i> Factor | Number of Tubes Volume/Size | Rotor Capacity |
|----------|---------------|-----------------|--|----------------|
| 7 500 | 10 580 | 4 140 | 12 x 50 mL (conical) 29 x 103 mm 1.125 x 4 in | 600 mL |

50-mL Round-Bottom Tube Carrier

No. 362214. Multitube Carrier for 50-mL round-bottom tubes. Holds four tubes per carrier for maximum rotor capacity of 16 x 50-mL tubes. Set of two.



Major applications: General-purpose centrifugation.

| Max. RPM | Max. <i>g</i> | <i>k</i> Factor | Number of Tubes Volume/Size | Rotor Capacity |
|----------|---------------|-----------------|---|----------------|
| 7 500 | 10 080 | 3 959 | 16 x 50 mL 29 x 104 mm 1.125 x 4 in | 800 mL |

5-mL Round-Bottom Tube Carrier

No. 362215. Multitube Carrier for 5-mL round-bottom tubes. Holds 24 tubes per carrier for maximum rotor capacity of 96 x 5-mL tubes. Set of two.



Major applications: RIA and other multitube assays.

| Max. RPM | Max. <i>g</i> | <i>k</i> Factor | Number of Tubes Volume/Size | Rotor Capacity |
|----------|---------------|-----------------|---------------------------------------|----------------|
| 7 500 | 8 950 | 2 818 | 96 x 5 mL 12 x 75 mm 0.5 x 3 in | 480 mL |

* Ficoll-Paque is a registered trademark of Pharmacia Fine Chemicals.

Tubes for 250-mL Bucket

Tubes and Bottles

| Tube Style/Material | Nominal Volume per Tube (mL) | Part No. | Quantity | Size (mm) | Required Adapters | Tubes per Adapter | g-Force | k Factor | Maximum Speed |
|------------------------------------|------------------------------|----------|----------|-----------|-------------------|-------------------|---------|----------|---------------|
| Bottles with Screw Caps | | | | | | | | | |
| Polycarbonate | 50.0 | 357002 | 25 | 29 x 104 | 356997 | 1 | 9 000 | ----- | 7 500 |
| | 250.0 | 355673 | 6 | 62 x 136 | 336389 | 1 | 10 400 | 5 290 | 7 500 |
| Polypropylene | 50.0 | 357003 | 25 | 29 x 104 | 356997 | 1 | 9 000 | ----- | 7 500 |
| Bottles with Cap Assemblies | | | | | | | | | |
| Polycarbonate | 50.0 | 355603 | 6 | 16 x 76 | 356997 | 1 | 9 000 | ----- | 7 500 |
| | 50.0 | 355600 | 6 | 29 x 104 | 356997 | 1 | 9 000 | ----- | 7 500 |
| Conical Polycarbonate | 230.0 | 356987 | 6 | 62 x 141 | 356983 | 1 | 10 400 | 5 290 | 7 500 |
| Wide-mouth Polycarbonate | 250.0 | 356013 | 6 | 62 x 120 | ----- | ----- | 10 400 | 5 290 | 7 500 |
| Conical Polypropylene | 230.0 | 356989 | 6 | 62 x 141 | 356983 | 1 | 10 400 | 5 290 | 7 500 |
| Wide-mouth Polypropylene | 250.0 | 356011 | 6 | 62 x 120 | ----- | ----- | 10 400 | 5 290 | 7 500 |
| Tubes with Snap-On Caps | | | | | | | | | |
| Polycarbonate | 50.0 | 363664 | 25 | 29 x 104 | 356997 | 1 | 9 000 | ----- | 7 500 |
| Polypropylene | 50.0 | 357005 | 25 | 29 x 104 | 356997 | 1 | 9 000 | ----- | 7 500 |
| Open Top Tubes | | | | | | | | | |
| Polycarbonate (Graduated) | 50.0 | 363647 | 25 | 29 x 104 | ----- | ----- | 10 080 | 5 290 | 7 500 |
| Polypropylene (Graduated) | 50.0 | 357007 | 25 | 29 x 104 | 356964 | 4 | 9 000 | ----- | 7 500 |
| BioVials | | | | | | | | | |
| Polypropylene | 4.0 | 566353 | 1000 | 14 x 55 | 342098* | 9 | ----- | ----- | 7 500 |

* Adapter 342098 can be double-stacked to increase rotor capacity.

Adapters

See chart on page 2-6 for adapters used with non-Beckman Coulter tubes and bottles.



Tubes for 4-place Carrier

Tubes and Bottles

| Tube Style/Material | Nominal Volume per Tube (mL) | Part No. | Quantity | Size (mm) | Required Adapters | Tubes per Adapter | g-Force | k Factor | Maximum Speed |
|--------------------------------|------------------------------|----------|----------|-----------|-------------------|-------------------|---------|----------|---------------|
| Bottles with Screw Caps | | | | | | | | | |
| Polyallomer | 50.0 | 357003 | 25 | 29 x 104 | ---- | ---- | 10 400 | ---- | 7 500 |
| Polycarbonate | 50.0 | 357002 | 25 | 29 x 104 | ---- | ---- | 10 400 | ---- | 7 500 |
| Tubes with Snap Caps | | | | | | | | | |
| Polycarbonate | 50.0 | 363664* | 25 | 29 x 104 | ---- | ---- | 10 400 | ---- | 7 500 |
| Polypropylene | 50.0 | 357005* | 25 | 29 x 104 | ---- | ---- | 10 400 | ---- | 7 500 |
| Open-Top Tubes | | | | | | | | | |
| Polycarbonate | 50.0 | 363647 | 25 | 29 x 104 | ---- | ---- | 10 400 | ---- | 7 500 |

* See Rotor Manual for instructions on positioning these tubes in the carrier.
See chart on page 2-6 for adapters used with non-Beckman Coulter tubes and bottles.

Rotor Replacement Parts

- 885367 Retaining Ring for Rotor Knob Shaft if purchased after 1/1/81. If purchased before 1/1/81, use 885367 and 336747.
- 816952 Polyethylene Rotor Foot
- 362216 250-mL Buckets (set of 2)
- 362212 JS-7.5 Rotor without carriers or buckets
- 364920 Tie-down Kit
- 362213 3 x 50 mL Conical Multitube Carriers (set of 2)
- 362214 4 x 50 mL Round-bottom Multitube Carriers (set of 2)
- 362215 24 x 5 mL Round-bottom Multitube Carriers (set of 2)

Adapters

See chart on page 2-6 for adapters used with non-Beckman Coulter tubes and bottles.



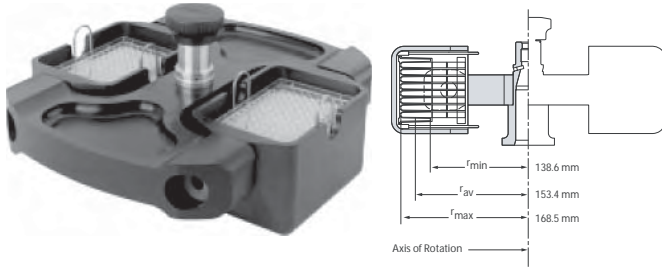

Swinging-Bucket Rotor

Major applications: High-throughput processing (DNA or RNA kits), serial dilution of small volumes.

| Max. RPM | Max. g | Rotor Capacity | Approximate Accel/Decel Time (sec) |
|----------|--------|----------------|------------------------------------|
| 5 900 | 6 570 | 10 Microplates | 47/49 |

For use in Avanti® J-25 Series and Avanti J-30I centrifuges.

No. 369331. JS-5.9 Swinging-Bucket Rotor Assembly. Two-place rotor with removable aluminum swinging buckets (set of two), microplate carriers (set of two), support pad for microplates (set of four), and tie-down.

Microplates

| Plate or Tube Style/Material | Nominal Volume per Well | Part No. | Quantity | No. of Wells | g-Force | k Factor | Maximum Speed |
|--|-------------------------|----------|----------|--------------|---------|----------|---------------|
| Multiwell Plate, Polystyrene, Nonsterile | 300 µL | 609844 | 100 | 96 wells | --- | --- | 5 900 |
| Deep-well Plate, Polystyrene, Nonsterile* | 1 mL | 267001 | 24 | 96 wells | --- | --- | 5 900 |
| Deep-well Plate, Polystyrene, Sterile* | 1 mL | 267004 | 24 | 96 wells | --- | --- | 5 900 |
| Deep-well Plate, Polypropylene, Nonsterile | 1 mL | 267006 | 24 | 96 wells | --- | --- | 5 900 |
| Deep-well Plate, Polypropylene, Sterile | 1 mL | 267007 | 24 | 96 wells | --- | --- | 5 900 |
| Square-well Plate, Polypropylene | 2 mL | 140504 | 24 | 96 wells | --- | --- | 5 900 |

Accessories

- 267002 Cap Strip, Nonsterile[†] (pkg. of 12)
- 267005 Cap Strip, Sterile[†] (pkg. of 12)
- 538619 Aluminum Foil Lid[‡] (pkg. of 100)
- 368957 Support Pad for Microplates (set of 4)
- 538618 Rubber Roller, 4-inch, for sealing microplate lids
- 339558 Rotor Cleaning Kit
- 339555 Beckman Coulter Solution 555 (1 qt)
- 339379 Rotor Cleaning Brush
- 977212 Paint On Graphite Lubricant (1/2 oz)

Rotor Replacement Parts

- 368919 Bucket (set of 2)
- 368920 Microplate Carrier (set of 2)

* Do not stack these plates.

† Caps are optional.

‡ Requires 4-inch soft rubber roller (538618) for installation.

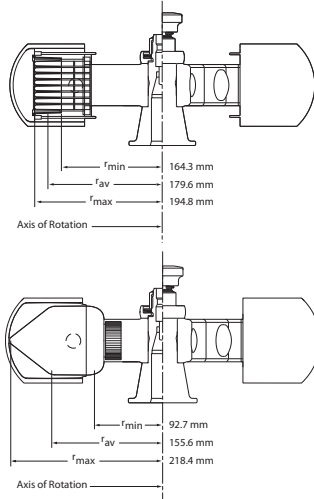

Swinging-Bucket Rotor, Anodized Aluminum

Major applications: Rapid sedimentation of protein precipitates, large particles, cells, and cell debris. It can be used for binding studies and separating serum from whole blood.

| Max. RPM | Max. g | Number of Tubes Volume | Rotor Capacity |
|----------|--------|---------------------------|----------------|
| 5 300 | 6 870 | 4 x 500 mL | 2 L |
| 5 300 | 6 130 | 24 microplates | 2 L |

For use in Avanti® J-E and J-26 XP Series centrifuges only.

No. 368690. JS-5.3 Swinging-Bucket Rotor. Four-place rotor with anodized aluminum buckets designed for use with adapters to accommodate a wide range of tubes and bottles. Rotor buckets are interchangeable with microplate carriers. Includes tie-down knob.

No. 969314. JS-5.3 Swinging-Bucket Rotor Package. Includes rotor, buckets, tie-down knob, and microplate carrier kit (368314).

Microplate Carrier Kit

No. 368914. Microplate Carrier Kit. Includes 4 carriers (368905) and 4 support pads (369382).

Replacement Parts for Microplate Carriers

| | |
|--------|--|
| 369382 | Support Pads (set of 4) |
| 368905 | Microplate Carrier (set of 4) |
| 368417 | Aeroseal™ Covers for JS-5.3 AllSpin Rotor (set of 2)  |
| 368706 | Bucket Upgrade Kit (set of 4 blue buckets)*** |

Tubes and Bottles

| Size | Required Adapter (pkg. 4) | Adapter Color | Tubes per Adapter | g-Force* | Maximum Speed |
|---|---------------------------|---------------|-------------------|----------|---------------|
| 5 mL round, 13 mm diameter, variable lengths | 392071 | Beige | 33 | 6 145 | 5 300 |
| 10 mL round, 16 mm diameter, variable lengths | 392072 | Purple | 24 | 6 145 | 5 300 |
| 15 mL round, 17 mm diameter, variable lengths | 392073 | Red | 20 | 6 145 | 5 300 |
| 15 mL conical, 17 mm diameter, variable lengths | 392075 | Green | 18 | 6 425† | 5 300 |
| 50 mL round, 29 mm diameter, variable lengths | 392074 | Yellow | 8 | 6 145 | 5 300 |
| 50 mL conical, 30 x 115 mm | 392076 | Black | 7 | 6 480† | 5 300 |
| 250 mL round/230 mL conical | 392077 | Yellow | 1 | 6 670 | 5 300‡ |
| 250 mL conical, 60 x 172 mm | 392079 | Orange | 1 | 6 870 | 5 300 |
| 500 mL conical | 392078 | Blue | 1 | 6 870 | 5 300 |
| 15 mL conical | 356964 (each) | Yellow | 1 | 6 670 | 5 300″ |
| 50 mL conical | 356966 (each) | Yellow | 1 | 6 670 | 5 300″ |

* Maximum RCF and speed for adapters. Use manufacturers' recommendations for tube and bottle limits.
 ** Use this adapter inside the 250-mL adapter (392077) to run tubes at 6 670 x g.
 *** Rotors with black buckets require Bucket Upgrade Kit 368706
 † Maximum RCF for labware tested in this adapter is 4 000 x g. Use manufacturers' recommendations for max g-force.
 ‡ Requires a cushion (356983) to be placed at bottom of adapter.

Adapters

See chart on page 2–6 for adapters used with non-Beckman Coulter tubes and bottles.



| Description | Volume | Part No. | Quantity | Maximum Speed | Accessory Description* | Part No. | Quantity |
|--|-------------|----------|----------|---------------|------------------------|----------|----------|
| Labware | | | | | | | |
| Multiwell Polystyrene Plate, 96-Well, Nonsterile | 300 µL/well | 609844 | 100 | 5 300 | Cap Strip, Nonsterile† | 267002 | 12 |
| | | | | | Cap Strip, Sterile† | 267005 | 12 |
| | | | | | Aluminum Foil Lid‡ | 538619 | 100 |
| Deep-Well Polystyrene Plate, 96-Well, Nonsterile | 1 mL/well | 267001 | 24 | 5 300 | Cap Strip, Nonsterile | 267002 | 12 |
| | | | | | Cap Strip, Sterile | 267005 | 12 |
| | | | | | Aluminum Foil Lid | 538619 | 100 |
| Deep-Well Polystyrene Plate, 96-Well, Sterile | 1 mL/well | 267004 | 24 | 5 300 | Cap Strip, Nonsterile | 267002 | 12 |
| | | | | | Cap Strip, Sterile | 267005 | 12 |
| | | | | | Aluminum Foil Lid | 538619 | 100 |
| Deep-Well Polypropylene Plate, 96-Well, Nonsterile | 1 mL/well | 267006 | 24 | 5 300 | Cap Strip, Nonsterile | 267002 | 12 |
| | | | | | Cap Strip, Sterile | 267005 | 12 |
| | | | | | Aluminum Foil Lid | 538619 | 100 |
| Deep-Well Polypropylene Plate, 96-Well, Sterile | 1 mL/well | 267007 | 24 | 5 300 | Cap Strip, Nonsterile | 267002 | 12 |
| | | | | | Cap Strip, Sterile | 267005 | 12 |
| | | | | | Aluminum Foil Lid | 538619 | 100 |
| Square-Well Polystyrene Plate, | 2 mL/well | 140504 | 24 | 5 300 | Aluminum Foil Lid | 538619 | 100 |

* When stacking polypropylene multiwell plates, place a support pad (369382) beneath the bottom plate and a cap strip between the plates to prevent breakage during centrifugation. Also use the support pad beneath all polystyrene deep-well plates.

† Caps are optional.

‡ Requires 4-inch soft-rubber roller (538618) for installation.

Rotor Replacement Parts

| | |
|--------|-------------------------------|
| 368690 | JS-5.3 rotor assembly |
| 368410 | Rotor tie-down knob |
| 368415 | Bucket (set of 4) |
| 368914 | Microplate carrier kit |
| | Contains: |
| 368905 | Microplate carrier (set of 4) |
| 369382 | Support pad (set of 4) |

Rotor Supplies

| | |
|--|--|
| Replacement tube and bottle adapters (set of 2): | |
| 368907 | Beige (13 mm dia) |
| 368909 | Purple (16 mm dia) |
| 368910 | Red (17 mm dia) |
| 368911 | Yellow (29 mm dia) |
| 368915 | Green (15 mL conical) |
| 368916 | Black (50 mL conical) |
| 369385 | Orange (250 mL conical) |
| 369383 | Yellow (250 mL round/230 mL conical) |
| 369384 | Blue (500 mL conical) |
| 538618 | Rubber Roller, 4-in., for sealing foil microplate lids |
| 339558 | Rotor Cleaning Kit |
| 339555 | Beckman Solution 555 (1 qt) |
| 339379 | Rotor Cleaning Brush |
| 977212 | Paint On Graphite Lubricant (1/2 oz) |

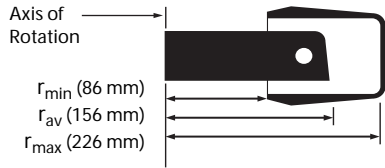
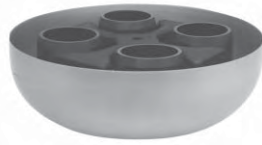

Swinging-Bucket Rotor (Windshielded)

Major applications: Rapid sedimentation of protein precipitates, large particles, cells, and cell debris. It can be used for binding studies and separating serum from whole blood.

| Max. RPM | Max. <i>g</i> | Rotor Capacity | Approximate Accel/Decel Time (min:sec) |
|----------|---------------|---|--|
| 5 200 | 6 840 | 4 Liters, 4 Blood Bags, 12 Microplates, 148 RIA-Tubes | 2:00/2:30 |

For use in J6-MI centrifuge.

No. 339087. JS-5.2 Swinging-Bucket Biosafety Rotor. Windshielded, four-place rotor with aluminum rotor yoke and removable aluminum swinging buckets. Buckets are interchangeable with Microplate Carriers for spinning microtiter plates and MiniTube Racks.

Tubes and Bottles

| Tube Style/Material | Nominal Volume per Tube (mL) | Part No. | Quantity | Size (mm) | Required Adapters | Tubes per Adapter | <i>g</i> -Force | <i>k</i> Factor | Maximum Speed |
|------------------------------------|------------------------------|----------|----------|-----------|-------------------|-------------------|-----------------|-----------------|---------------|
| Bottles with Screw Caps | | | | | | | | | |
| Polyallomer | 50.0 | 357003 | 25 | 29 x 104 | 339103 | 7 | ----- | ----- | 5 200 |
| Polycarbonate | 10.0 | 355672 | 25 | 16 x 80 | 341977 | 19 | ----- | ----- | 5 200 |
| | 50.0 | 357002 | 25 | 29 x 104 | 339103 | 7 | ----- | ----- | 5 200 |
| | 750.0 | 358299 | 6 | 96 x 130 | 356096 | 1 | ----- | ----- | 5 200 |
| | 1000.0 | 355675 | 6 | 97 x 167 | 356096 | 1 | ----- | ----- | 5 200 |
| Round-bottom Polycarbonate | 250.0 | 355673 | 6 | 62 x 136 | 339108 | 1 | ----- | ----- | 5 200 |
| Wide-mouth Polycarbonate | 500.0 | 355664 | 6 | 69 x 160 | 339109 | 1 | ----- | ----- | 5 200 |
| Polypropylene | 750.0 | 356855 | 6 | 96 x 130 | 356096 | 1 | ----- | ----- | 5 200 |
| | 1000.0 | 355676 | 6 | 97 x 167 | 356096 | 1 | ----- | ----- | 5 200 |
| Wide-mouth Polypropylene | 500.0 | 355665 | 6 | 69 x 159 | 339109 | 1 | ----- | ----- | 5 200 |
| Bottles with Cap Assemblies | | | | | | | | | |
| Polyallomer | 50.0 | 357001 | 6 | 29 x 104 | 339103 | 7 | ----- | ----- | 5 200 |
| Polycarbonate | 50.0 | 357000 | 6 | 29 x 104 | 339103 | 7 | ----- | ----- | 5 200 |
| | 70.0 | 355620 | 6 | 38 x 102 | 339104 | 2 | ----- | ----- | 5 200 |
| Wide-mouth Polycarbonate | 250.0 | 356013 | 6 | 62 x 122 | 339108 | 1 | ----- | ----- | 5 200 |
| | 500.0 | 355605 | 6 | 69 x 160 | 339109 | 1 | ----- | ----- | 5 200 |
| Polypropylene | 100.0 | 355624 | 6 | 38 x 102 | 339104 | 2 | ----- | ----- | 5 200 |
| Wide-mouth Polypropylene | 250.0 | 356011 | 6 | 62 x 122 | 339108 | 1 | ----- | ----- | 5 200 |
| | 500.0 | 355607 | 6 | 69 x 160 | 339109 | 1 | ----- | ----- | 5 200 |

* When used with optional AeroSeal™ Covers, P/N 343686.

Adapters

See chart on page 2–6 for adapters used with non-Beckman Coulter tubes and bottles.



Tubes and Bottles (continued)

| Tube Style/Material | Nominal Volume per Tube (mL) | Part No. | Quantity | Size (mm) | Required Adapters | Tubes per Adapter | <i>g</i> -Force | <i>k</i> Factor | Maximum Speed | |
|--------------------------------|------------------------------|----------|----------|-----------|-------------------|-------------------|-----------------|-----------------|---------------|-------|
| Bottles | | | | | | | | | | |
| Polycarbonate | 70.0 | 355655 | 6 | 38 x 102 | 339104 | 2 | ----- | ----- | 5 200 | |
| | 500.0 | 355649 | 6 | 69 x 160 | 339109 | 1 | ----- | ----- | 5 200 | |
| Wide-mouth Polycarbonate | 250.0 | 358275 | 25 | 62 x 122 | 339108 | 1 | ----- | ----- | 5 200 | |
| Polypropylene | 100.0 | 355626 | 6 | 38 x 102 | 339104 | 2 | ----- | ----- | 5 200 | |
| | 500.0 | 355650 | 6 | 69 x 159 | 339109 | 1 | ----- | ----- | 5 200 | |
| Wide-mouth Polypropylene | 250.0 | 358326 | 25 | 62 x 120 | 339108 | 1 | ----- | ----- | 5 200 | |
| Conical Tubes | | | | | | | | | | |
| Polycarbonate with cap | 230.0 | 356987 | 6 | 62 x 141 | 356983/339108 | 1 | ----- | ----- | 5 200 | |
| Polypropylene with cap | 230.0 | 356989 | 6 | 62 x 141 | 356983/339108 | 1 | ----- | ----- | 5 200 | |
| Tubes with Snap-On Caps | | | | | | | | | | |
| Polyallomer | Natural | 1.5 | 357448 | 500 | 11 x 38 | 339100/354511 | 26 | ----- | ----- | 5 200 |
| Polycarbonate | | 50.0 | 363664 | 25 | 29 x 104 | 339103 | 7 | ----- | ----- | 5 200 |
| Polyethylene | | 1.8 | 340196 | 500 | 11 x 39 | 339100/354511 | 26 | ----- | ----- | 5 200 |
| Polypropylene | Orange | 1.5 | 356094 | 500 | 11 x 38 | 339100/354511 | 26 | ----- | ----- | 5 200 |
| | Yellow | 1.5 | 356093 | 500 | 11 x 38 | 339100/354511 | 26 | ----- | ----- | 5 200 |
| | Green | 1.5 | 356092 | 500 | 11 x 38 | 339100/354511 | 26 | ----- | ----- | 5 200 |
| | Blue | 1.5 | 356091 | 500 | 11 x 38 | 339100/354511 | 26 | ----- | ----- | 5 200 |
| | Natural | 1.5 | 356090 | 500 | 11 x 38 | 339100/354511 | 26 | ----- | ----- | 5 200 |
| | Natural* | 1.5 | 343169 | 500 | 11 x 38 | 339100/354511 | 26 | ----- | ----- | 5 200 |
| Polypropylene | | 50.0 | 357005 | 25 | 29 x 104 | 339103 | 7 | ----- | ----- | 5 200 |

* Cap separate.

Adapters

See chart on page 2–6 for adapters used with non-Beckman Coulter tubes and bottles.



Tubes and Bottles (continued)

| Tube Style/Material | Nominal Volume per Tube (mL) | Part No. | Quantity | Size (mm) | Required Adapters | Tubes per Adapter | g-Force | k Factor | Maximum Speed |
|-----------------------|------------------------------|----------|----------|-----------|-------------------|-------------------|---------|----------|---------------|
| Open-Top Tubes | | | | | | | | | |
| Polyallomer | 10.0 | 355640 | 25 | 16 x 76 | 341977 | 19 | ---- | ---- | 5 200 |
| Polycarbonate | 10.0 | 355630 | 25 | 16 x 76 | 341977 | 19 | ---- | ---- | 5 200 |
| | 15.0 | 342080 | 100 | 18 x 98 | 339102 | 14 | ---- | ---- | 5 200 |
| | 50.0 | 363647 | 25 | 29 x 104 | 339103 | 7 | ---- | ---- | 5 200 |
| Polyethylene | 15.0 | 342081 | 100 | 18 x 98 | 339102 | 14 | ---- | ---- | 5 200 |
| Polypropylene | 15.0 | 342080 | 100 | 18 x 98 | 339102 | 14 | ---- | ---- | 5 200 |
| | 50.0 | 357007 | 25 | 29 x 104 | 339103 | 7 | ---- | ---- | 5 200 |
| BioVials | | | | | | | | | |
| Polypropylene | 4.0 | 566353 | 1000 | 14 x 55 | 339101 | 24 | ---- | ---- | 5 200 |

Blood-Bag Cups

No. 339127. Yellow cup with inner diameter of 88 mm for single- and double-packs. Set of four.

No. 339129. Set of four. Red cup with inner diameter of 98 mm for triple- and quad-packs. Set of four.



AeroSeal™ Covers 

No. 343686. Cover for round buckets of JS-5.2. Features O-ring seal to provide added aerosol protection. Transparent so broken tubes can be detected and proper precautions taken before breaking seal. Quantity 1.



Microplate Carriers

No. 358680. Special carriers, interchangeable with buckets, slip onto yoke of JS-5.2 Rotor. Each carrier holds three microplates for a total capacity of 12 per run. Maximum speed 2 600 rpm (1450 x g). Set of two.



Rotor Supplies

- 339031 Rotor Tie-down Screw
- 341710 Bucket Set (set of 4)
- 878439 Torquing Bar for Rotor Tie-down Screw
- 367045 Rotor Tie-down Kit for Avanti® J-26 XP Series centrifuge

Adapters

See chart on page 2–6 for adapters used with non-Beckman Coulter tubes and bottles.



JS-5.0

4 x 2.25 L

JS-5.0

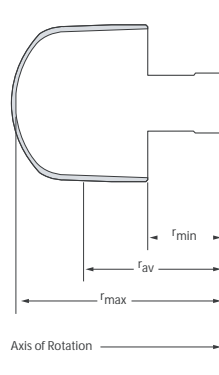

Swinging-Bucket Rotor, Anodized Aluminum

Major applications: Separating bacterial, yeast, and tissue homogenates; harvesting cultures.

| Max. RPM | Max. <i>g</i> | <i>k</i> Factor | Number of Containers | Rotor Capacity |
|----------|---------------|-----------------|----------------------|----------------|
| 5 000 | 7 480 | 9 171 | 4 x 2.25 L | 9 L |

For use in Avanti® J-HC centrifuges.

1

No. 367820. JS-5.0 Swinging-Bucket Rotor Assembly with Labware Kit. Four-place rotor with anodized aluminum buckets. Includes 4 cups, 4 cup covers with plugs, 8 red cup gaskets, 4 green liner gaskets, 60 air vent filters, 50 HarvestLine™ system liners, 2 cup racks, 1 spatula.

No. 368968. JS-5.0 Swinging-Bucket Rotor Assembly.

Labware Kit

No. 368732. Includes 4 cups, 4 cup covers with plugs, 8 red cup gaskets, 4 green liner gaskets, 60 air vent filters, 50 HarvestLine™ system liners, 2 cup racks, 1 spatula.

Container Assembly

No. 368730. Includes 4 cups, 4 covers with plugs, and 4 cup gaskets (369257).

HarvestLine System Liners

No. 368735. Set of 50 polyethylene system liners (food grade compliant).

Rotor Accessories

- 368727 Rack
- 367891 Spatula (set of 2)
- 369259 Partition (set of 4)
- 367837 Buckets (set of 4)
- 369257 Gaskets, Cup (red, set of 4)
- 369261 Gaskets, Liner (green, set of 4)
- 977212 Paint-on Graphite Lubricant
- 339558 Rotor Cleaning Kit
- 339555 Solution 555™ (1 qt)
- 306812 Spinkote™ Lubricant (2 oz)

Rotor Replacement Parts

- 346965 Rotor Removal Tool
- 367824 Tie-down Bolt
- 368521 Tie-down Tool

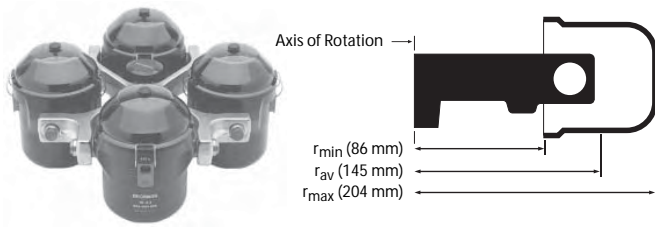

Swinging-Bucket Rotor, Anodized Aluminum

Major applications: Rapid sedimentation of protein precipitates, large particles, cells, and cell debris. It can be used for binding studies and separating serum from whole blood.

| Max. RPM | Max. g | k Factor | Number of Tubes Volume/Size | Rotor Capacity |
|----------|--------|----------|---|----------------|
| 4 300 | 4 220 | 11 800 | 4 x 750 mL 96 x 130 mm 3.8 x 5.2 in | 3 L |

For use in Avanti® J-26 XP Series and J-HC centrifuges.

No. 362734. JS-4.3 Swinging-Bucket Biosafety Rotor. Four-place rotor with anodized aluminum buckets designed for use with modular disk adapters to accommodate a variety of tubes (as indicated in the chart below) and other adapters and blood bag cups. Can be used with

Bucket Covers

No. 361264. Set of two. Transparent bucket covers for JS-4.3 Buckets to contain broken tubes. Includes gasket and clips.

Aerosolve® Cannisters

No. 359232. Set of four.
No. 359481. Set of two.
Aerosolve Cannisters fit in JS-4.3 Rotor Buckets. These cannisters feature an O-ring seal and are completely transparent so a broken tube can be seen and proper precautions taken before you break the seal. Cannisters can also be used as 500-mL wide-mouth bottles. Specially-designed adapters accommodate most popular tubes within the cannister (see table at end of this rotor section).

Beckman Coulter Aerosolve® Cannisters which are designed to provide added protection from aerosols. Rotor buckets are interchangeable with microplate carriers.

MicroPlus Carriers

No. 362394. MicroPlus Carrier Assembly. Includes carrier, base, and rubber pad to cushion plates. Each carrier can hold up to 3 microplates, 1 deep-well/square well plate, 1 rack of MiniTubes, or other labware in 96-well format. Set of 2. Maximum allowable speed is 3,250 rpm (1924 x g).

Replacement Parts for MicroPlus Carrier

- 361302 Base and Rubber Pads (set of 2)
- 362390 Rubber Pads (set of 4)
- 361304 MicroPlus Carriers (set of 2)

Tubes and Bottles

| Tube Style/Material | Nominal Volume per Tube (mL) | Part No. | Quantity | Size (mm) | Required Adapters Set of 2/Set of 4 | Tubes per Adapter | g-Force | k Factor | Maximum Speed |
|----------------------------------|------------------------------|----------|----------|-----------|-------------------------------------|-------------------|----------------|----------|----------------|
| Bottles with Screw Caps | | | | | | | | | |
| Polyallomer | 50.0 | 357003 | 25 | 29 x 104 | 359474/359153 359486/359164 | 7 4 | 3 830 | — | 4 300 |
| Polycarbonate | 50.0 | 357002 | 25 | 29 x 104 | 359474/359153 359486/359164 | 7 4 | 3 830 3 670 | — | 4 300 4 300 |
| | 250.0 | 355673 | 6 | 62 x 136 | 349946 (ea.) | 1 | 4 040 | — | 4 300 |
| | 750.0 | 358299 | 6 | 96 x 130 | 349846 (ea.) | 1 | 4 040 | — | 4 300 |
| Wide-mouth Polycarbonate | 250.0 | 356013 | 6 | 62 x 122 | 349946 (ea.) | 1 | 4 040 | — | 4 300 |
| Conical Wide-mouth Polycarbonate | 230.0 | 356987 | 6 | 62 x 141 | 356983 and 349946* 356985 (ea.) | 1 | 4 040 | — | 4 300 |
| Polypropylene | 750.0 | 356855 | 6 | 96 x 130 | 349846 (ea.) | 1 | 4 040 | — | 4 300 |
| Wide-mouth Polypropylene | 250.0 | 356011 | 6 | 62 x 122 | 349946 (ea.) | 1 | 4 040 | — | 4 300 |
| | 500.0 | 355665 | 6 | 69 x 159 | 349945 (ea.) | 1 | 4 150 | — | 4 300 |
| Conical Wide-mouth Polypropylene | 230.0 | 356989 | 6 | 62 x 141 | 356983 and 349946* 356985 (ea.) | 1 | 4 040 | — | 4 300 |

* Use adapter 356983 with adapter 349946.

Adapters

See chart on page 2–6 for adapters used with non-Beckman Coulter tubes and bottles.

- 349846 349945 349946 356983 356985 359474 359486



Tubes and Bottles (continued)

| Tube Style/Material | Nominal Volume per Tube (mL) | Part No. | Quantity | Size (mm) | Required Adapters Set of 2/Set of 4 | Tubes per Adapter | g-Force | k Factor | Maximum Speed |
|------------------------------------|------------------------------|----------|----------|-----------|-------------------------------------|-------------------|---------|----------|---------------|
| Bottles with Cap Assemblies | | | | | | | | | |
| Polyallomer | 50.0 | 357001 | 6 | 29 x 104 | 359474/359153 359486/359164 | 7 4 | ----- | ----- | 4 300 |
| Polycarbonate | 50.0 | 357000 | 6 | 29 x 104 | 359474/359153 359486/359164 | 7 4 | ----- | ----- | 4 300 |
| Wide-mouth Polycarbonate | 250.0 | 356013 | 6 | 62 x 122 | 349946 (ea.) | 1 | ----- | ----- | 4 300 |
| Wide-mouth Polypropylene | 500.0 | 355607 | 6 | 69 x 160 | 349945 (ea.) | 1 | ----- | ----- | 4 300 |
| | 500.0 | 355665 | 6 | 69 x 159 | 349945 (ea.) | 1 | ----- | ----- | 4 300 |
| | 250.0 | 356011 | 6 | 62 x 122 | 349946 (ea.) | 1 | ----- | ----- | 4 300 |
| Bottles | | | | | | | | | |
| Wide-mouth Polycarbonate | 250.0 | 358275 | 25 | 62 x 122 | 349946 (ea.) | 1 | ----- | ----- | 4 300 |
| Polypropylene | 500.0 | 355650 | 6 | 69 x 159 | 349945 (ea.) | 1 | ----- | ----- | 4 300 |
| Wide-mouth Polypropylene | 250.0 | 358326 | 25 | 62 x 120 | 349946 (ea.) | 1 | ----- | ----- | 4 300 |
| Conical Tubes | | | | | | | | | |
| Wide-mouth Conical Polycarbonate | 230.0 | 356987 | 6 | 62 x 141 | 356983 and 349946 | 1 | ----- | ----- | 4 300 |
| Wide-mouth Conical Polypropylene | 230.0 | 356989 | 6 | 62 x 141 | 356983 and 349946 | 1 | ----- | ----- | 4 300 |
| Open-Top Tubes | | | | | | | | | |
| Polyallomer | 10.0 | 355640 | 25 | 16 x 76 | 359471/359150 | 19 | ----- | ----- | 4 300 |
| | | | | | 359484/359162 | 12 | | | |
| Polycarbonate | 10.0 | 355630 | 25 | 16 x 76 | 359471/359150 | 19 | ----- | ----- | 4 300 |
| | | | | | 359484/359162 | 12 | | | |
| | | | | | 359473/359152 | 14 | | | |
| | | | | | 359474/359153 | 7 | | | |
| Polyethylene | 15.0 | 342080 | 100 | 18 x 98 | 359473/359152 | 14 | ----- | ----- | 4 300 |
| | | | | | 359474/359153 | 7 | | | |
| | | | | | 359486/359164 | 4 | | | |
| Polypropylene | 50.0 | 363664 | 25 | 29 x 104 | 359474/359153 | 7 | ----- | ----- | 4 300 |
| | | | | | 359486/359164 | 4 | | | |
| | | | | | 359471/359150 | 7 | | | |
| Stainless Steel | 10.0 | 301108 | 1 | 16 x 76 | 359471/359150 | 7 | ----- | ----- | 4 300 |
| | | | | | 359484/359162 | 4 | | | |

Adapters

See chart on page 2–6 for adapters used with non-Beckman Coulter tubes and bottles.



Tubes and Bottles (continued)

| Tube Style/Material | Nominal Volume per Tube (mL) | Part No. | Quantity | Size (mm) | Required Adapters Set of 2/Set of 4 | Tubes per Adapter | g-Force | k Factor | Maximum Speed |
|--------------------------------|------------------------------|----------|----------|-----------|--|-------------------|---------|----------|---------------|
| Tubes with Snap-On Caps | | | | | | | | | |
| Polyallomer | 1.5 | 357448 | 500 | 11 x 38 | 359469/359148 354511 (ea.)* 354495 (ea.) | 26 26 | ---- | ---- | 4 300 |
| Polyethylene | Natural | 340196 | 500 | 11 x 39 | 359469/359148 354511 (ea.)* 354495 (ea.) | 26 26 | ---- | ---- | 4 300 |
| Polypropylene | | 357005 | 25 | 29 x 104 | 359474/359153 359486/359164 | 7 4 | ---- | ---- | 4 300 |
| | Natural† | 343169 | 500 | 11 x 38 | 359469/359148 354511 (ea.)* 354495 (ea.) | 26 26 | ---- | ---- | 4 300 |
| | Natural† | 356090 | 500 | 11 x 38 | 359469/359148 354511 (ea.)* 354495 (ea.) | 26 26 | ---- | ---- | 4 300 |
| | Blue | 356091 | 500 | 11 x 38 | 359469/359148 354511 (ea.)* 354495 (ea.) | 26 26 | ---- | ---- | 4 300 |
| | Green | 356092 | 500 | 11 x 38 | 359469/359148 354511 (ea.)* 354495 (ea.) | 26 26 | ---- | ---- | 4 300 |
| | Yellow | 356093 | 500 | 11 x 38 | 359469/359148 354511 (ea.)* 354495 (ea.) | 26 26 | ---- | ---- | 4 300 |
| | Orange | 356094 | 500 | 11 x 38 | 359469/359148 354511 (ea.)* 354495 (ea.) | 26 26 | ---- | ---- | 4 300 |
| | Green | 356092 | 500 | 11 x 38 | 359469/359148 354511 (ea.)* 354495 (ea.) | 26 26 | ---- | ---- | 4 300 |
| BioVials | | | | | | | | | |
| Polypropylene | 4.0 | 566353 | 1 000 | 14 x 55 | 359470/359149 344517 (ea.) | 24 10 | ---- | ---- | 4 300 |

* Tube retainer (P/N 354511) is sold separately.

† Cap separate.

Adapters

See chart on page 2–6 for adapters used with non-Beckman Coulter tubes and bottles.



| Aerosolve® Cannisters | | | | | | | Part No. |
|-------------------------------------|---------------------------------|----------------------------|-------------------|------------------------|--------------------------------------|--------------------------------------|----------|
| Aerosolve Cannisters for JS-4.3 | | | | | | | 343686 |
| Aerosolve Cannister Adapters | | | | | | | |
| Color Code | Typical Tube/Bottle Volume (mL) | Maximum Tube Diameter (mm) | Tubes per Adapter | Tubes per JS-4.3 Rotor | Adapter Assembly Part No. (set of 4) | Adapter Assembly Part No. (set of 2) | |
| White | 1.5 | 11 | 24 | 96 | 354495 | ----- | |
| Blue | 3 and 5 | 12 | 24 | 96 | 359482 | 359160 | |
| Tan | 5 | 13 | 24 | 96 | 359489 | 358993 | |
| Orange | 10 | 14 | 18 | 72 | 359483 | 359161 | |
| Purple | 12 | 16 | 12 | 48 | 359484 | 359162 | |
| | 3 and 5 | 12 | 6 | 24 | | | |
| White (vials) | 15 | 14 | 10 | 40 | 344517 | ----- | |
| Green | 15 and 20 | 18 | 12 | 48 | 359485 | 359163 | |
| | 3 and 5 | 12 | 6 | 24 | | | |
| Light Green (conical) | 15 | 17 | 6 | 24 | 359487 | 358991 | |
| | 3 and 5 | 12 | 6 | 24 | | | |
| Lime Green (conical) | 50 | 30 | 4 | 16 | 359488 | 358992 | |
| | 3 and 5 | 12 | 6 | 24 | | | |
| Yellow | 50 | 70 | 1 | 4 | 359486 | 359164 | |
| | 3 and 5 | 12 | 4 | 16 | | | |
| Cannister Kit | 500 | --- | --- | --- | 359481 | 359232 | |

Rotor Replacement Parts

- 361261 Aluminum Buckets, weight-matched set of 4
- 361251 Rotor Yoke, forged stainless steel
- 361264 Bucket Cover Kit
- 361304 MicroPlus Multiwell Plate Carriers, with bases and pads (set of 2)
- 361302 Replacement Bases for MicroPlus Carriers, with pads (set of 2)
- 362390 Replacement Pads for MicroPlus Carriers (set of 4)
- 362737 Knob Assembly

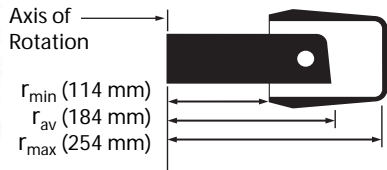

Swinging-Bucket Rotor (Windshielded)

Major applications: Rapid sedimentation of protein precipitates, large particles, cells, and cell debris. It can be used for binding studies and separating serum from whole blood.

| Max. RPM | Max. g | Rotor Capacity | Approximate Accel/Decel Time (min:sec) |
|----------|--------|---|--|
| 4 200 | 5 020 | 6 Liters, 6 Blood Bags, 18 Microplates, 336 RIA-Tubes | 2:30/3:00 |

For use in Avanti® J-HC and J6-MI centrifuges only.

No. 339080. JS-4.2 Swinging-Bucket Biosafety Rotor. Windshielded, six-place rotor with aluminum rotor yoke and removable aluminum swinging

buckets. Buckets are interchangeable with Microplate Carriers 358682[‡] for spinning microtiter plates and MiniTube Racks.

Tubes and Bottles

| Tube Style/Material | Nominal Volume per Tube (mL) | Part No. | Quantity | Size (mm) | Required Adapters (Multi-Disc™) Set of 2/Set of 4 | Tubes per Adapter | g-Force | k Factor | Maximum Speed |
|------------------------------------|------------------------------|----------------------|----------|------------|---|-------------------|---------|----------|---------------|
| Bottles with Screw Caps | | | | | | | | | |
| Polyallomer | 50.0 | 357003 | 25 | 29 x 104 | 359474/359153 359486*/259164* | 7 | 5 020 | ----- | 4 200 |
| Polycarbonate | 10.0 | 355672 | 25 | 16 x 80 | 341977 | 19 | 5 020 | ----- | 4 200 |
| | 50.0 | 357002 | 25 | 29 x 104 | 339103 | 7 | 5 020 | ----- | 4 200 |
| | 250.0 | 355673 | 6 | 62 x 136 | 339108 | 1 | 5 020 | ----- | 4 200 |
| | 750.0 | 358299 [‡] | 6 | 96 x 130 | 349946 | 1 | 5 020 | ----- | 4 200 |
| Wide-mouth Polycarbonate | 500.0 | 355664 | 6 | 69 x 160 | 339109 | 1 | 5 020 | ----- | 4 200 |
| Polypropylene | 750.0 | 356855 ^{††} | 6 | 96 x 130 | 356096 | 1 | 5 020 | ----- | 4 200 |
| | 1000.0 | 355676 ^{††} | 6 | 97 x 167 | 356096 | 1 | 5 020 | ----- | 4 200 |
| Wide-mouth Polypropylene | 500.0 | 355665 | 6 | 69 x 159 | 339109 | 1 | 5 020 | ----- | 4 200 |
| Teflon | 50.0 | 363076 | 8 | 28.5 x 107 | 359474/359153 359486*/259164* | 7 | 5 020 | ----- | 4 200 |
| Bottles with Cap Assemblies | | | | | | | | | |
| Polyallomer | 50.0 | 357001 | 6 | 29 x 104 | 339103 | 7 | 5 020 | ----- | 4 200 |
| Polycarbonate | 50.0 | 357000 | 6 | 29 x 104 | 339103 | 7 | 5 020 | ----- | 4 200 |
| | 70.0 | 355620 | 6 | 38 x 102 | 339104 | 2 | 5 020 | ----- | 4 200 |
| Wide-mouth Polycarbonate | 250.0 | 356013 | 6 | 62 x 122 | 339108 | 1 | 5 020 | ----- | 4 200 |
| | 500.0 | 355605 | 6 | 69 x 160 | 339109 | 1 | 5 020 | ----- | 4 200 |
| Polypropylene | 100.0 | 355624 | 6 | 38 x 102 | 339104 | 2 | 5 020 | ----- | 4 200 |
| Wide-mouth Polypropylene | 250.0 | 356011 | 6 | 62 x 120 | 339108 | 1 | 5 020 | ----- | 4 200 |
| | 500.0 | 355607 | 6 | 69 x 160 | 339109 | 1 | 5 020 | ----- | 4 200 |
| Bottles | | | | | | | | | |
| Polycarbonate | 70.0 | 355655 | 6 | 38 x 102 | 339104 | 2 | 5 020 | ----- | 4 200 |
| | 500.0 | 355649 | 6 | 69 x 160 | 339109 | 1 | 5 020 | ----- | 4 200 |
| Wide-mouth Polycarbonate | 250.0 | 358275 | 25 | 62 x 122 | 339108 | 1 | 5 020 | ----- | 4 200 |
| Polypropylene | 100.0 | 355626 | 6 | 38 x 102 | 339104 | 2 | 5 020 | ----- | 4 200 |
| | 500.0 | 355650 | 6 | 69 x 159 | 339109 | 1 | 5 020 | ----- | 4 200 |
| Wide-mouth Polypropylene | 250.0 | 358326 | 25 | 62 x 120 | 339108 | 1 | 5 020 | ----- | 4 200 |

* When used with optional Aerosol™ Covers, P/N 343686.
† Adapter used in Aerosolve® Cannister (P/N 359232).

‡ Microplate carriers cannot be run in the Avanti J-HC centrifuge.
** These bottles require a sleeve rather than an adapter.

Adapters

See chart on page 2-6 for adapters used with non-Beckman Coulter tubes and bottles.



Tubes and Bottles (continued)

| Tube Style/Material | Nominal Volume per Tube (mL) | Part No. | Quantity | Size (mm) | Required Adapters (Multi-Disc™) | Tubes per Adapter | g-Force | k Factor | Maximum Speed | |
|--------------------------------|------------------------------|----------|----------|-----------|---------------------------------|-------------------|---------|----------|---------------|-------|
| Conical Tubes | | | | | | | | | | |
| Polycarbonate with cap | 230.0 | 356987* | 6 | 62 x 141 | 356983/349946† | 1 | 5 020 | ----- | 4 200 | |
| Polypropylene with cap | 230.0 | 356989* | 6 | 62 x 141 | 356983/349946† | 1 | 5 020 | ----- | 4 200 | |
| Tubes with Snap-On Caps | | | | | | | | | | |
| Polyallomer | Natural | 1.5 | 357448 | 500 | 11 x 38 | 339100/354511 | 26 | 5 020 | ----- | 4 200 |
| | Orange | 1.5 | 357444 | 500 | 11 x 38 | 339100/354511 | 26 | 5 020 | ----- | 4 200 |
| | Yellow | 1.5 | 357445 | 500 | 11 x 38 | 339100/354511 | 26 | 5 020 | ----- | 4 200 |
| | Green | 1.5 | 357446 | 500 | 11 x 38 | 339100/354511 | 26 | 5 020 | ----- | 4 200 |
| | Blue | 1.5 | 357447 | 500 | 11 x 38 | 339100/354511 | 26 | 5 020 | ----- | 4 200 |
| Polycarbonate | 50.0 | 363664 | 25 | 29 x 104 | 356997 | 1 | 5 020 | ----- | 4 200 | |
| Polyethylene | Natural | 1.8 | 340196 | 500 | 11 x 39 | 339100/354511 | 26 | 5 020 | ----- | 4 200 |
| Polypropylene | | 50.0 | 357005 | 25 | 29 x 104 | 339103 | 7 | 5 020 | ----- | 4 200 |
| | Natural‡ | 1.5 | 343169 | 500 | 11 x 38 | 339100/354511 | 26 | 5 020 | ----- | 4 200 |
| | Natural | 1.5 | 356090 | 500 | 11 x 38 | 339100/354511 | 26 | 5 020 | ----- | 4 200 |
| | Blue | 1.5 | 356091 | 500 | 11 x 38 | 339100/354511 | 26 | 5 020 | ----- | 4 200 |
| | Green | 1.5 | 356092 | 500 | 11 x 38 | 339100/354511 | 26 | 5 020 | ----- | 4 200 |
| | Yellow | 1.5 | 356093 | 500 | 11 x 38 | 339100/354511 | 26 | 5 020 | ----- | 4 200 |
| | Orange | 1.5 | 356094 | 500 | 11 x 38 | 339100/354511 | 26 | 5 020 | ----- | 4 200 |

BioVials

* These tubes cannot be run with bucket covers in place.

† Adapter 356983 may be used with 349946.

‡ Cap separate.

Adapters

See chart on page 2–6 for adapters used with non-Beckman Coulter tubes and bottles.



| | | | | | | | | | |
|---------------|-----|--------|-------|---------|--------|----|-------|-------|-------|
| Polypropylene | 4.0 | 566353 | 1 000 | 14 x 55 | 339101 | 24 | 5 020 | ----- | 4 200 |
|---------------|-----|--------|-------|---------|--------|----|-------|-------|-------|

Tubes and Bottles (continued)

| Tube Style/Material | Nominal Volume per Tube (mL) | Part No. | Quantity | Size (mm) | Required Adapters (Multi-Disc™) | Tubes per Adapter | g-Force | k Factor | Maximum Speed |
|-----------------------|------------------------------|----------|----------|-----------|---------------------------------|-------------------|---------|----------|---------------|
| Open-Top Tubes | | | | | | | | | |
| Polyallomer | 10.0 | 355640 | 25 | 16 x 76 | 341977 | 19 | 5 020 | ----- | 4 200 |
| Polycarbonate | 10.0 | 355630 | 25 | 16 x 76 | 341977 | 19 | 5 020 | ----- | 4 200 |
| | 15.0 | 342080 | 100 | 18 x 98 | 339102 | 14 | 5 020 | ----- | 4 200 |
| | 50.0 | 363647 | 25 | 29 x 104 | 339103 | 7 | 5 020 | ----- | 4 200 |
| Polyethylene | 15.0 | 342081 | 100 | 18 x 98 | 339102 | 14 | 5 020 | ----- | 4 200 |
| Polypropylene | 15.0 | 342082 | 100 | 18 x 98 | 339102 | 14 | 5 020 | ----- | 4 200 |
| | 50.0 | 357007 | 25 | 29 x 104 | 339103 | 7 | 5 020 | ----- | 4 200 |
| Stainless Steel | 10.0 | 301108 | 1 | 16 x 76 | 341977 | 19 | 5 020 | ----- | 4 200 |

Blood-Bag Cups

No. 339127. Yellow cup with inner diameter of 88 mm for single- and double-packs. Set of two.

No. 339129. Red cup with inner diameter of 98 mm for triple- and quad-packs. Set of two.



Aeroseal™ Covers



No. 343686. Cover for round buckets of JS-4.2. Features O-ring seal to provide added aerosol protection. Transparent so broken tubes can be detected and proper precautions taken before breaking seal. Quantity 1.



Microplate Carriers

No. 358682. Special carriers, interchangeable with buckets, slip onto yoke of JS-4.2 Rotor. Each carrier holds three microplates for a total capacity of 18 per run. Max. speed 2 500 rpm. Set of two.



Rotor Replacement Parts

- 367045 Rotor Tie-down Kit
- 348392 Cover Assembly
- 368575 Buckets (qty: 6, blue-anodized)
- 368574 Bucket (qty: 1, blue-anodized)
- 339096 Bail for Adapter

Adapters

See chart on page 2–6 for adapters used with non-Beckman Coulter tubes and bottles.

339102 339103 341977



JS-4.2A

Biosafety

6 x 1000 mL

JS-4.2A

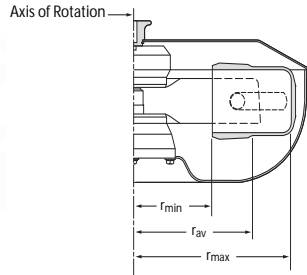

Swinging-Bucket Rotor (Windshielded)

Major applications: Rapid sedimentation of protein precipitates, large particles, cells, and cell debris. It can be used for binding studies and separating serum from whole blood.

| Max. RPM | Max. g | Rotor Capacity | Approximate Accel/Decel Time (min:sec) |
|----------|--------|---|--|
| 4 200 | 5 020 | 6 Liters, 6 Blood Bags, 18 Microplates, 336 RIA-Tubes | 2:30/3:00 |

For use in Avanti® J-HC and J6-MI centrifuges only.

No. 36695. JS-4.2A Swinging-Bucket Biosafety Rotor. Windshielded, six-place rotor with aluminum rotor yoke and removable aluminum swinging buckets. Buckets are interchangeable with Microplate Carriers

358682[†] for spinning microtiter plates and MiniTube Racks. ARIES “Smart Balance” technology provides imbalance compensation for rotors with buckets that are unbalanced up to 100 grams.

Tubes and Bottles

| Tube Style/Material | Nominal Volume per Tube (mL) | Part No. | Quantity | Size (mm) | Required Adapters (Multi-Disc™) | Tubes per Adapter | g-Force | k Factor | Maximum Speed |
|------------------------------------|------------------------------|----------|----------|-----------|---------------------------------|-------------------|---------|----------|---------------|
| Bottles with Screw Caps | | | | | | | | | |
| Polyallomer | 50.0 | 357003 | 25 | 29 x 104 | 339103 | 7 | 5 020 | ----- | 4 200 |
| Polycarbonate | 10.0 | 355672 | 25 | 16 x 80 | 341977 | 19 | 5 020 | ----- | 4 200 |
| | 50.0 | 357002 | 25 | 29 x 104 | 339103 | 7 | 5 020 | ----- | 4 200 |
| | 750.0 | 358299* | 6 | 96 x 130 | 356096 | 1 | 5 020 | ----- | 4 200 |
| | 1000.0 | 355675* | 6 | 97 x 167 | 356096 | 1 | 5 020 | ----- | 4 200 |
| Round-bottom Polycarbonate | 250.0 | 355673 | 6 | 62 x 136 | 339108 | 1 | 5 020 | ----- | 4 200 |
| Wide-mouth Polycarbonate | 500.0 | 355664 | 6 | 69 x 160 | 339109 | 1 | 5 020 | ----- | 4 200 |
| Polypropylene | 750.0 | 356855* | 6 | 96 x 130 | 356096 | 1 | 5 020 | ----- | 4 200 |
| | 1000.0 | 355676* | 6 | 97 x 167 | 356096 | 1 | 5 020 | ----- | 4 200 |
| Wide-mouth Polypropylene | 500.0 | 355665 | 6 | 69 x 159 | 339109 | 1 | 5 020 | ----- | 4 200 |
| Bottles | | | | | | | | | |
| Polycarbonate | 70.0 | 355655 | 6 | 38 x 102 | 339104 | 2 | 5 020 | ----- | 4 200 |
| | 500.0 | 355649 | 6 | 69 x 160 | 339109 | 1 | 5 020 | ----- | 4 200 |
| Wide-mouth Polycarbonate | 250.0 | 358275 | 25 | 62 x 122 | 339108 | 1 | 5 020 | ----- | 4 200 |
| Polypropylene | 100.0 | 355626 | 6 | 38 x 102 | 339104 | 2 | 5 020 | ----- | 4 200 |
| | 500.0 | 355650 | 6 | 69 x 159 | 339109 | 1 | 5 020 | ----- | 4 200 |
| Wide-mouth Polypropylene | 250.0 | 358326 | 25 | 62 x 120 | 339108 | 1 | 5 020 | ----- | 4 200 |
| Bottles with Cap Assemblies | | | | | | | | | |
| Polyallomer | 50.0 | 357001 | 6 | 29 x 104 | 339103 | 7 | 5 020 | ----- | 4 200 |
| Polycarbonate | 50.0 | 357000 | 6 | 29 x 104 | 339103 | 7 | 5 020 | ----- | 4 200 |
| | 70.0 | 355620 | 6 | 38 x 102 | 339104 | 2 | 5 020 | ----- | 4 200 |
| Wide-mouth Polycarbonate | 250.0 | 356013 | 6 | 62 x 122 | 339108 | 1 | 5 020 | ----- | 4 200 |
| | 500.0 | 355605 | 6 | 69 x 160 | 339109 | 1 | 5 020 | ----- | 4 200 |
| Polypropylene | 100.0 | 355624 | 6 | 38 x 102 | 339104 | 2 | 5 020 | ----- | 4 200 |
| Wide-mouth Polypropylene | 250.0 | 356011 | 6 | 62 x 120 | 339108 | 1 | 5 020 | ----- | 4 200 |
| | 500.0 | 355607 | 6 | 69 x 160 | 339109 | 1 | 5 020 | ----- | 4 200 |

[†] Microplate carriers cannot be run in the Avanti J-HC centrifuge.

* These bottles require a sleeve rather than an adapter.

Adapters

See chart on page 2–6 for adapters used with non-Beckman Coulter tubes and bottles.

339103 339104 339108 339109 341977 356096



Tubes and Bottles (continued)

| Tube Style/Material | Nominal Volume per Tube (mL) | Part No. | Quantity | Size (mm) | Required Adapters (Multi-Disc™) | Tubes per Adapter | g-Force | k Factor | Maximum Speed | |
|--------------------------------|------------------------------|----------|----------|-----------|---------------------------------|-------------------|---------|----------|---------------|-------|
| Conical Tubes | | | | | | | | | | |
| Polycarbonate with cap | 230.0 | 356987 | 6 | 62 x 141 | 356983/339108 | 1 | 5 020 | ----- | 4 200 | |
| Polypropylene with cap | 230.0 | 356989 | 6 | 62 x 141 | 356983/339108 | 1 | 5 020 | ----- | 4 200 | |
| Tubes with Snap-On Caps | | | | | | | | | | |
| Polyallomer | Natural | 1.5 | 357448 | 500 | 11 x 38 | 339100/354511 | 26 | 5 020 | ----- | 4 200 |
| | Orange | 1.5 | 357444 | 500 | 11 x 38 | 339100/354511 | 26 | 5 020 | ----- | 4 200 |
| | Yellow | 1.5 | 357445 | 500 | 11 x 38 | 339100/354511 | 26 | 5 020 | ----- | 4 200 |
| | Green | 1.5 | 357446 | 500 | 11 x 38 | 339100/354511 | 26 | 5 020 | ----- | 4 200 |
| | Blue | 1.5 | 357447 | 500 | 11 x 38 | 339100/354511 | 26 | 5 020 | ----- | 4 200 |
| Polycarbonate | 50.0 | 363664 | 25 | 29 x 104 | 356997 | 1 | | | 4 200 | |
| Polyethylene | Natural | 1.8 | 340196 | 500 | 11 x 39 | 339100/354511 | 26 | 5 020 | ----- | 4 200 |
| Polypropylene | | 50.0 | 357005 | 25 | 29 x 104 | 339103 | 7 | 5 020 | ----- | 4 200 |
| | Natural | 1.5 | 356090 | 500 | 11 x 38 | 339100/354511 | 26 | 5 020 | ----- | 4 200 |
| | Natural | 1.5 | 343169 | 500 | 11 x 38 | 339100/354511 | 26 | 5 020 | ----- | 4 200 |
| | Blue | 1.5 | 356091 | 500 | 11 x 38 | 339100/354511 | 26 | 5 020 | ----- | 4 200 |
| | Green | 1.5 | 356092 | 500 | 11 x 38 | 339100/354511 | 26 | 5 020 | ----- | 4 200 |
| | Yellow | 1.5 | 356093 | 500 | 11 x 38 | 339100/354511 | 26 | 5 020 | ----- | 4 200 |
| | Orange | 1.5 | 356094 | 500 | 11 x 38 | 339100/354511 | 26 | 5 020 | ----- | 4 200 |
| BioVials | | | | | | | | | | |
| Polypropylene | 4.0 | 566353 | 1 000 | 14 x 55 | 339101 | 24 | 5 020 | ----- | 4 200 | |

Adapters

See chart on page 2–6 for adapters used with non-Beckman Coulter tubes and bottles.



Tubes and Bottles (continued)

| Tube Style/Material | Nominal Volume per Tube (mL) | Part No. | Quantity | Size (mm) | Required Adapters (Multi-Disc™) | Tubes per Adapter | g-Force | k Factor | Maximum Speed |
|-----------------------|------------------------------|----------|----------|-----------|---------------------------------|-------------------|---------|----------|---------------|
| Open-Top Tubes | | | | | | | | | |
| Polyallomer | 10.0 | 355640 | 25 | 16 x 76 | 341977 | 19 | 5 020 | ----- | 4 200 |
| Polycarbonate | 10.0 | 355630 | 25 | 16 x 76 | 341977 | 19 | 5 020 | ----- | 4 200 |
| | 15.0 | 342080 | 100 | 18 x 98 | 339102 | 14 | 5 020 | ----- | 4 200 |
| | 50.0 | 363647 | 25 | 29 x 104 | 339103 | 7 | 5 020 | ----- | 4 200 |
| Polyethylene | 15.0 | 342081 | 100 | 18 x 98 | 339102 | 14 | 5 020 | ----- | 4 200 |
| Polypropylene | 15.0 | 342082 | 100 | 18 x 98 | 339102 | 14 | 5 020 | ----- | 4 200 |
| | 50.0 | 357007 | 25 | 29 x 104 | 339103 | 7 | 5 020 | ----- | 4 200 |
| Stainless Steel | 10.0 | 301108 | 1 | 16 x 76 | 341977 | 19 | 5 020 | ----- | 4 200 |

Blood-Bag Cups

No. 339127. Yellow cup with inner diameter of 88 mm for single- and double-packs. Set of two.

No. 339129. Red cup with inner diameter of 98 mm for triple- and quad-packs. Set of two.



Aeroseal™ Covers



No. 343686. Cover for round buckets of JS-4.2A. Features O-ring seal to provide added aerosol protection. Transparent so broken tubes can be detected and proper precautions taken before breaking seal. Quantity 1.



Microplate Carriers

No. 358682. Special carriers, interchangeable with buckets, slip onto yoke of JS-4.2A Rotor. Each carrier holds three microplates for a total capacity of 18 per run. Max. speed 2 500 rpm. Set of two.



Rotor Replacement Parts

- 367045 Rotor Tie-down Kit
- 348392 Cover Assembly
- 368575 Buckets (qty: 6, blue-anodized)
- 368574 Bucket (qty: 1, blue-anodized)

Adapters

See chart on page 2–6 for adapters used with non-Beckman Coulter tubes and bottles.

339102 339103 341977



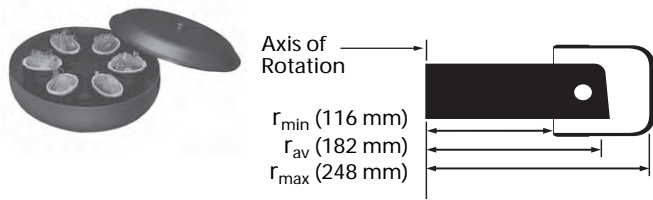

Swinging-Bucket Rotor (Windshielded)

Major applications: Separation of serum from whole blood, blood component separation.

| Max. RPM | Max. <i>g</i> | Rotor Capacity | Approximate Accel/Decel Time (min:sec) |
|----------|---------------|--------------------------------|--|
| 4 200 | 4 900 | 6 Blood Bags 18 Microplates | 2:30/3:00 |

For use in J6-MI centrifuge only.

No. 348394. JS-4.2SM Swinging-Bucket Rotor. Windshielded, six-place rotor designed with oval-shaped buckets specifically for blood bank applications which utilize similarly shaped blood bags. Buckets are interchangeable with microplate carriers for blood serum studies. Includes six oval-shaped blood-bag cups.

Microplate Carriers

No. 358682. Special carriers, interchangeable with buckets, slip onto yoke of JS-4.2SM Rotor. Each carrier holds three microplates for a total capacity of 18 per run. Maximum speed 2 500 rpm. Set of two.



Blood-Bag Cups

No. 363651. Oval-shaped gray cup for quad-packs (filters). Set of two.



Rotor Replacement Parts

- 367045 Rotor Tie-down Kit
- 348392 Cover Assembly
- 348393 Buckets (set of 6)
- 348359 Liners

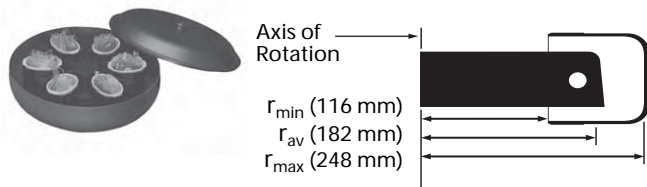

Swinging-Bucket Rotor (Windshielded)

Major applications: Separation of serum from whole blood, blood component separation.

| Max. RPM | Max. g | Rotor Capacity | Approximate Accel/Decel Time (min:sec) |
|----------|--------|----------------|--|
| 4 200 | 4 900 | 6 Blood Bags | 2:30/3:00 |

For use in J6-MI centrifuge only.

No. 366670. JS-4.2SMA Swinging-Bucket Rotor. Windshielded, six-place rotor designed with oval-shaped buckets specifically for blood bank applications which utilize similarly shaped blood bags. Buckets are interchangeable with microplate carriers for blood serum studies. Includes six oval-shaped blood-bag cups. ARIES “Smart Balance” technology provides imbalance compensation for rotors with buckets that are unbalanced up to 100 grams.

Microplate Carriers

No. 358682. Special carriers, interchangeable with buckets, slip onto yoke of JS-4.2SMA Rotor. Each carrier holds three microplates for a total capacity of 18 per run. Maximum speed 2 500 rpm. Set of two.



Blood-Bag Cups

No. 363651. Oval-shaped gray cup for quad-packs (filters). Set of two.



Rotor Replacement Parts

- 367045 Rotor Tie-down Kit
- 348392 Cover Assembly
- 348393 Buckets (set of 6)
- 348359 Liners

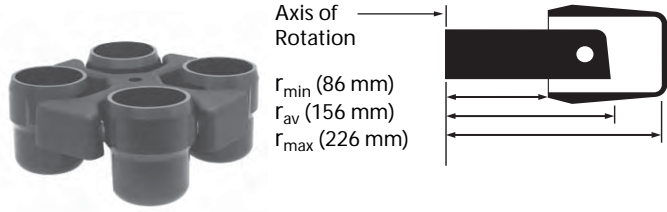

Swinging-Bucket Rotor (Unshielded), Aluminum

Major applications: Rapid sedimentation of protein precipitates, large particles, cells, and cell debris. It can be used for binding studies and separating serum from whole blood.

| Max. RPM | Max. g | Rotor Capacity | Approximate Accel/Decel Time |
|----------|--------|---|------------------------------|
| 4 000 | 4 050 | 4 Liters, 4 Blood Bags, 12 Microplates, 148 RIA Tubes | 1:30/2:00 min. |

For use in Avanti® J-26 XP Series and J6-MI centrifuges.

No. 339086. JS-4.0 Swinging-Bucket Biosafety Rotor. Unshielded, four-place rotor with aluminum rotor yoke and removable aluminum swinging buckets. Buckets are interchangeable with Microplate Carriers for spinning microtiter plates and MiniTube Racks.
Note: requires tie-down kit P/N 367045 for use with Avanti J-26 XP Series centrifuges.

* When used with optional AeroSeal™ Covers P/N 343686.

Tubes and Bottles

| Tube Style/Material | Nominal Volume per Tube (mL) | Part No. | Quantity | Size (mm) | Required Adapters | Tubes per Adapter | g-Force | k Factor | Maximum Speed |
|------------------------------------|------------------------------|----------|----------|-----------|-------------------|-------------------|---------|----------|---------------|
| Bottles with Screw Caps | | | | | | | | | |
| Polyallomer | 50.0 | 357003 | 25 | 29 x 104 | 339103 | 7 | ----- | ----- | 4 000 |
| Polycarbonate | 10.0 | 355672 | 25 | 16 x 80 | 341977 | 19 | ----- | ----- | 4 000 |
| | 50.0 | 357002 | 25 | 29 x 104 | 339103 | 7 | ----- | ----- | 4 000 |
| | 750.0 | 358299 | 6 | 96 x 130 | 356096 | 1 | ----- | ----- | 4 000 |
| | 1000.0 | 355675 | 6 | 97 x 167 | 356096 | 1 | ----- | ----- | 4 000 |
| Round-bottom Polycarbonate | 250.0 | 355673 | 6 | 62 x 136 | 339108 | 1 | ----- | ----- | 4 000 |
| Wide-mouth Polycarbonate | 500.0 | 355664 | 6 | 69 x 160 | 339109 | 1 | ----- | ----- | 4 000 |
| Polypropylene | 750.0 | 356855 | 6 | 96 x 130 | 356096 | 1 | ----- | ----- | 4 000 |
| | 1000.0 | 355676 | 6 | 97 x 167 | 356096 | 1 | ----- | ----- | 4 000 |
| Wide-mouth Polypropylene | 500.0 | 355665 | 6 | 69 x 159 | 339109 | 1 | ----- | ----- | 4 000 |
| Bottles with Cap Assemblies | | | | | | | | | |
| Polyallomer | 50.0 | 357001 | 6 | 29 x 104 | 339103 | 7 | ----- | ----- | 4 000 |
| Polycarbonate | 50.0 | 357000 | 6 | 29 x 104 | 339103 | 7 | ----- | ----- | 4 000 |
| | 70.0 | 355620 | 6 | 38 x 102 | 339104 | 2 | ----- | ----- | 4 000 |
| Wide-mouth Polycarbonate | 250.0 | 356013 | 6 | 62 x 122 | 339108 | 1 | ----- | ----- | 4 000 |
| | 500.0 | 355605 | 6 | 69 x 160 | 339109 | 1 | ----- | ----- | 4 000 |
| Polypropylene | 100.0 | 355624 | 6 | 38 x 102 | 339104 | 2 | ----- | ----- | 4 000 |
| Wide-mouth Polypropylene | 250.0 | 356011 | 6 | 62 x 122 | 339108 | 1 | ----- | ----- | 4 000 |
| | 500.0 | 355607 | 6 | 69 x 160 | 339109 | 1 | ----- | ----- | 4 000 |

Adapters

See chart on page 2–6 for adapters used with non-Beckman Coulter tubes and bottles.



Tubes and Bottles (continued)

| Tube Style/Material | Nominal Volume per Tube (mL) | Part No. | Quantity | Size (mm) | Required Adapters | Tubes per Adapter | g-Force | k Factor | Maximum Speed | |
|--------------------------------|------------------------------|----------|----------|-----------|-------------------|-------------------|---------|----------|---------------|-------|
| Bottles | | | | | | | | | | |
| Polycarbonate | 70.0 | 355655 | 6 | 38 x 102 | 339104 | 2 | ----- | ----- | 4 000 | |
| | 500.0 | 355649 | 6 | 69 x 160 | 339109 | 1 | ----- | ----- | 4 000 | |
| Wide-mouth Polycarbonate | 250.0 | 358275 | 25 | 62 x 122 | 339108 | 1 | ----- | ----- | 4 000 | |
| Polypropylene | 100.0 | 355626 | 6 | 38 x 102 | 339104 | 2 | ----- | ----- | 4 000 | |
| | 500.0 | 355650 | 6 | 69 x 159 | 339109 | 1 | ----- | ----- | 4 000 | |
| Wide-mouth Polypropylene | 250.0 | 358326 | 25 | 62 x 120 | 339108 | 1 | ----- | ----- | 4 000 | |
| Conical Tubes | | | | | | | | | | |
| Polycarbonate with cap | 230.0 | 356987 | 6 | 62 x 141 | 356983/339108 | 1 | ----- | ----- | 4 000 | |
| Polypropylene with cap | 230.0 | 356989 | 6 | 62 x 141 | 356983/339108 | 1 | ----- | ----- | 4 000 | |
| Tubes with Snap-On Caps | | | | | | | | | | |
| Polyallomer | Natural | 1.5 | 357448 | 500 | 11 x 38 | 339100/354511 | 26 | ----- | ----- | 4 000 |
| Polycarbonate | | 50.0 | 363664 | 25 | 29 x 104 | 339103 | 7 | ----- | ----- | 4 000 |
| Polyethylene | | 1.8 | 340196 | 500 | 11 x 39 | 339100/354511 | 26 | ----- | ----- | 4 000 |
| Polypropylene | Orange | 1.5 | 356094 | 500 | 11 x 38 | 339100/354511 | 26 | ----- | ----- | 4 000 |
| | Yellow | 1.5 | 356093 | 500 | 11 x 38 | 339100/354511 | 26 | ----- | ----- | 4 000 |
| | Green | 1.5 | 356092 | 500 | 11 x 38 | 339100/354511 | 26 | ----- | ----- | 4 000 |
| | Blue | 1.5 | 356091 | 500 | 11 x 38 | 339100/354511 | 26 | ----- | ----- | 4 000 |
| | Natural | 1.5 | 356090 | 500 | 11 x 38 | 339100/354511 | 26 | ----- | ----- | 4 000 |
| | Natural* | 1.5 | 343169 | 500 | 11 x 38 | 339100/354511 | 26 | ----- | ----- | 4 000 |
| Polypropylene | | 50.0 | 357005 | 25 | 29 x 104 | 339103 | 7 | ----- | ----- | 4 000 |

* Cap separate.

Adapters

See chart on page 2–6 for adapters used with non-Beckman Coulter tubes and bottles.



Tubes and Bottles (continued)

| Tube Style/Material | Nominal Volume per Tube (mL) | Part No. | Quantity | Size (mm) | Required Adapters | Tubes per Adapter | <i>g</i> -Force | <i>k</i> Factor | Maximum Speed |
|-----------------------|------------------------------|----------|----------|-----------|-------------------|-------------------|-----------------|-----------------|---------------|
| Open-Top Tubes | | | | | | | | | |
| Polyallomer | 10.0 | 355640 | 25 | 16 x 76 | 341977 | 19 | ---- | ---- | 4 000 |
| Polycarbonate | 10.0 | 355630 | 25 | 16 x 76 | 341977 | 19 | ---- | ---- | 4 000 |
| | 15.0 | 342080 | 100 | 18 x 98 | 339102 | 14 | ---- | ---- | 4 000 |
| | 50.0 | 363647 | 25 | 29 x 104 | 339103 | 7 | ---- | ---- | 4 000 |
| Polyethylene | 15.0 | 342081 | 100 | 18 x 98 | 339102 | 14 | ---- | ---- | 4 000 |
| Polypropylene | 15.0 | 342082 | 100 | 18 x 98 | 339102 | 14 | ---- | ---- | 4 000 |
| | 50.0 | 357007 | 25 | 29 x 104 | 339103 | 7 | ---- | ---- | 4 000 |
| BioVials | | | | | | | | | |
| Polypropylene | 4.0 | 566353 | 1000 | 14 x 55 | 339101 | 24 | ---- | ---- | 4 000 |

Blood-Bag Cups

No. 339127. Yellow cup with inner diameter of 88 mm for single- and double-packs. Set of two.

No. 339129. Red cup with inner diameter of 98 mm for triple- and quad-packs. Set of two.



Aeroseal™ Covers



No. 343686. Cover for round buckets of JS-4.0. Features O-ring seal to provide added aerosol protection. Transparent so broken tubes can be detected and proper precautions taken before breaking seal. Quantity 1.



Microplate Carriers

No. 358680. Special carriers, interchangeable with buckets, slip onto yoke of JS-4.0 Rotor. Each carrier holds three microplates for a total capacity of 12 per run. Maximum speed 2 600 rpm (1450 x *g*). Set of two.



Rotor Supplies

- 339031 Rotor Tie-down Screw
- 341710 Bucket Set (set of 4)
- 878439 Torquing Bar for Rotor Tie-down Screw
- 367045 Rotor Tie-down Kit for Avanti® J-26 XP Series centrifuges

Adapters

See chart on page 2–6 for adapters used with non-Beckman Coulter tubes and bottles.



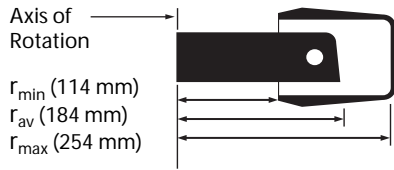

Swinging-Bucket Rotor (Unshielded)

Major applications: Major applications: Rapid sedimentation of protein precipitates, large particles, cells, and cell debris. It can be used for binding studies and separating serum from whole blood.

| Max. RPM | Max. g | Rotor Capacity | Approximate Accel/Decel Time (min:sec) |
|----------|--------|---|--|
| 3 000 | 2 560 | 6 Liters, 6 Blood Bags, 18 Microplates, 336 RIA-Tubes | 2:00/1:30 min. |

For use in J6-MI centrifuge only.

No. 339081. JS-3.0 Swinging-Bucket Biosafety Rotor. Unshielded, six-place rotor with aluminum rotor yoke and removable aluminum swinging buckets. Buckets are interchangeable with Microplate Carriers 358682 for spinning microtiter plates and MiniTube Racks in the JS-3.0 Rotor.

** When used with optional Aerosol™ Covers, P/N 343686.*

Tubes and Bottles

| Tube Style/Material | Nominal Volume per Tube (mL) | Part No. | Quantity | Size (mm) | Required Adapters (Multi-Disc™) | Tubes per Adapter | g-Force | k Factor | Maximum Speed |
|------------------------------------|------------------------------|----------|----------|-----------|---------------------------------|-------------------|---------|----------|---------------|
| Bottles with Screw Caps | | | | | | | | | |
| Polyallomer | 50.0 | 357003 | 25 | 29 x 104 | 339103 | 7 | 2 560 | ----- | 3 000 |
| Polycarbonate | 10.0 | 355672 | 25 | 16 x 80 | 341977 | 19 | 2 560 | ----- | 3 000 |
| | 50.0 | 357002 | 25 | 29 x 104 | 339103 | 7 | 2 560 | ----- | 3 000 |
| | 250.0 | 355673 | 6 | 62 x 136 | 339108 | 1 | 2 560 | ----- | 3 000 |
| | 750.0 | 358299 | 6 | 96 x 130 | 356096* | 1 | 2 560 | ----- | 3 000 |
| | 1000.0 | 355675 | 6 | 97 x 167 | 356096* | 1 | 2 560 | ----- | 3 000 |
| Wide-mouth Polycarbonate | 500.0 | 355664 | 6 | 69 x 160 | 339109 | 1 | 2 560 | ----- | 3 000 |
| Polypropylene | 750.0 | 356855 | 6 | 96 x 130 | 356096* | 1 | 2 560 | ----- | 3 000 |
| | 1000.0 | 355676 | 6 | 97 x 167 | 356096* | 1 | 2 560 | ----- | 3 000 |
| Wide-mouth Polypropylene | 500.0 | 355665 | 6 | 69 x 159 | 339109 | 1 | 2 560 | ----- | 3 000 |
| Bottles with Cap Assemblies | | | | | | | | | |
| Polyallomer | 50.0 | 357001 | 6 | 29 x 104 | 339103 | 7 | 2 560 | ----- | 3 000 |
| Polycarbonate | 50.0 | 357000 | 6 | 29 x 104 | 339103 | 7 | 2 560 | ----- | 3 000 |
| | 70.0 | 355620 | 6 | 38 x 102 | 339104 | 2 | 2 560 | ----- | 3 000 |
| Wide-mouth Polycarbonate | 250.0 | 356013 | 6 | 62 x 122 | 339108 | 1 | 2 560 | ----- | 3 000 |
| | 500.0 | 355605 | 6 | 69 x 160 | 339109 | 1 | 2 560 | ----- | 3 000 |
| Polypropylene | 100.0 | 355624 | 6 | 38 x 102 | 339104 | 2 | 2 560 | ----- | 3 000 |
| Wide-mouth Polypropylene | 250.0 | 356011 | 6 | 62 x 120 | 339108 | 1 | 2 560 | ----- | 3 000 |
| | 500.0 | 355607 | 6 | 69 x 160 | 339109 | 1 | 2 560 | ----- | 3 000 |
| Bottles | | | | | | | | | |
| Polycarbonate | 70.0 | 355655 | 6 | 38 x 102 | 339104 | 2 | 2 560 | ----- | 3 000 |
| | 500.0 | 355649 | 6 | 69 x 160 | 339109 | 1 | 2 560 | ----- | 3 000 |
| Wide-mouth Polycarbonate | 250.0 | 358275 | 25 | 62 x 122 | 339108 | 1 | 2 560 | ----- | 3 000 |
| Polypropylene | 100.0 | 355626 | 6 | 38 x 102 | 339104 | 2 | 2 560 | ----- | 3 000 |
| | 500.0 | 355650 | 6 | 69 x 159 | 339109 | 1 | 2 560 | ----- | 3 000 |
| Wide-mouth Polypropylene | 250.0 | 358326 | 25 | 62 x 120 | 339108 | 1 | 2 560 | ----- | 3 000 |

** These bottles require a sleeve rather than an adapter.*

Adapters

See chart on page 2–6 for adapters used with non-Beckman Coulter tubes and bottles.

339103 339104 339108 339109 341977 356096



Tubes and Bottles (continued)

| Tube Style/Material | Nominal Volume per Tube (mL) | Part No. | Quantity | Size (mm) | Required Adapters (Multi-Disc™) | Tubes per Adapter | g-Force | k Factor | Maximum Speed | |
|--------------------------------|------------------------------|----------|----------|-----------|---------------------------------|-------------------|---------|----------|---------------|-------|
| Conical Tubes | | | | | | | | | | |
| Polycarbonate with cap | 230.0 | 356987 | 6 | 62 x 141 | 356983/339108 | 1 | 2 560 | ----- | 3 000 | |
| Polypropylene with cap | 230.0 | 356989 | 6 | 62 x 141 | 356983/339108 | 1 | 2 560 | ----- | 3 000 | |
| Tubes with Snap-On Caps | | | | | | | | | | |
| Polyallomer | Natural | 1.5 | 357448 | 500 | 11 x 38 | 339100/354511 | 26 | 2 560 | ----- | 3 000 |
| | Orange | 1.5 | 357444 | 500 | 11 x 38 | 339100/354511 | 26 | 2 560 | ----- | 3 000 |
| | Yellow | 1.5 | 357445 | 500 | 11 x 38 | 339100/354511 | 26 | 2 560 | ----- | 3 000 |
| | Green | 1.5 | 357446 | 500 | 11 x 38 | 339100/354511 | 26 | 2 560 | ----- | 3 000 |
| | Blue | 1.5 | 357447 | 500 | 11 x 38 | 339100/354511 | 26 | 2 560 | ----- | 3 000 |
| Polycarbonate | 50.0 | 363664 | 25 | 29 x 104 | 356997 | 1 | 2 560 | ----- | 3 000 | |
| Polyethylene | Natural | 1.8 | 340196 | 500 | 11 x 39 | 339100/354511 | 26 | 2 560 | ----- | 3 000 |
| Polypropylene | | 50.0 | 357005 | 25 | 29 x 104 | 339103 | 7 | 2 560 | ----- | 3 000 |
| | Natural* | 1.5 | 343169 | 500 | 11 x 38 | 339100/354511 | 26 | 2 560 | ----- | 3 000 |
| | Natural | 1.5 | 356090 | 500 | 11 x 38 | 339100/354511 | 26 | 2 560 | ----- | 3 000 |
| | Blue | 1.5 | 356091 | 500 | 11 x 38 | 339100/354511 | 26 | 2 560 | ----- | 3 000 |
| | Green | 1.5 | 356092 | 500 | 11 x 38 | 339100/354511 | 26 | 2 560 | ----- | 3 000 |
| | Yellow | 1.5 | 356093 | 500 | 11 x 38 | 339100/354511 | 26 | 2 560 | ----- | 3 000 |
| | Orange | 1.5 | 356094 | 500 | 11 x 38 | 339100/354511 | 26 | 2 560 | ----- | 3 000 |
| BioVials | | | | | | | | | | |
| Polypropylene | 4.0 | 566353 | 1 000 | 14 x 55 | 339101 | 24 | 2 560 | ----- | 3 000 | |

* Cap separate.

Adapters

See chart on page 2-6 for adapters used with non-Beckman Coulter tubes and bottles.



Tubes and Bottles (continued)

| Tube Style/Material | Nominal Volume per Tube (mL) | Part No. | Quantity | Size (mm) | Required Adapters (Multi-Disc™) | Tubes per Adapter | g-Force | k Factor | Maximum Speed |
|-----------------------|------------------------------|----------|----------|-----------|---------------------------------|-------------------|---------|----------|---------------|
| Open-Top Tubes | | | | | | | | | |
| Polyallomer | 10.0 | 355640 | 25 | 16 x 76 | 341977 | 19 | 2 560 | ----- | 3 000 |
| Polycarbonate | 10.0 | 355630 | 25 | 16 x 76 | 341977 | 19 | 2 560 | ----- | 3 000 |
| | 15.0 | 342080 | 100 | 18 x 98 | 339102 | 14 | 2 560 | ----- | 3 000 |
| | 50.0 | 363647 | 25 | 29 x 104 | 339103 | 7 | 2 560 | ----- | 3 000 |
| Polyethylene | 15.0 | 342081 | 100 | 18 x 98 | 339102 | 14 | 2 560 | ----- | 3 000 |
| Polypropylene | 15.0 | 342082 | 100 | 18 x 98 | 339102 | 14 | 2 560 | ----- | 3 000 |
| | 50.0 | 357007 | 25 | 29 x 104 | 339103 | 7 | 2 560 | ----- | 3 000 |
| Stainless Steel | 10.0 | 301108 | 1 | 16 x 76 | 341977 | 19 | 2 560 | ----- | 3 000 |

Blood-Bag Cups

No. 339127. Yellow cup with inner diameter of 88 mm for single- and double-packs. Set of two.

No. 339129. Red cup with inner diameter of 98 mm for triple- and quad-packs. Set of two.



Aeroseal™ Covers 

No. 343686. Cover for round buckets of JS-3.0. Features O-ring seal to provide added aerosol protection. Transparent so broken tubes can be detected and proper precautions taken before breaking seal. Quantity 1.



Microplate Carriers

No. 358682. Special carriers, interchangeable with buckets, slip onto yoke of JS-3.0 Rotor. Each carrier holds three microplates for a total capacity of 18 per run. Max. speed 2 500 rpm. Set of two.



Rotor Replacement Parts

- 367045 Rotor Tie-down Kit
- 338392 Cover Assembly
- 368575 Buckets (set of 6, blue-anodized)

Adapters

See chart on page 2–6 for adapters used with non-Beckman Coulter tubes and bottles.

339102 339103 341977





How To Order the JCF-Z Rotor

For a complete Beckman Coulter JCF-Z Rotor system, the following components are required.

1. A JCF-Z Rotor (choose according to application; continuous flow, zonal, or reorienting gradient).
2. Optional high-flow seal assembly for processing up to 100 liters/hour.
3. An appropriate bracket assembly (for Avanti® J Series instruments only).
4. A pump system (not supplied by Beckman Coulter, but recommendations below).
5. A Beckman Coulter J2 Series or Avanti J Series centrifuge.

Continuous-Flow Rotors

No. 335140. JCF-Z Continuous-Flow Rotor, Titanium, Standard Pellet Core. Includes Standard continuous-flow core (pellet size 200 mL), standard-flow rotating seal assembly, and tool kit. Bracket kit required for use with Avanti J Series centrifuges, and pump system required for all applications.

| Max. RPM | Max. g | k Factor | Rotor Capacity |
|----------|--------|----------|----------------|
| 20 000 | 39 900 | 100 | 660 mL |

No. 357544. JCF-Z Continuous-Flow Rotor, Titanium, Small Pellet Core. Includes Small Pellet continuous-flow core (pellet size 200 mL), standard-flow rotating seal assembly, and tool kit. Bracket kit required for use with Avanti J Series centrifuges, and pump system required for all applications.

| Max. RPM | Max. g | k Factor | Rotor Capacity |
|----------|--------|----------|----------------|
| 20 000 | 36 300 | 281 | 240 mL |

No. 357521. JCF-Z Continuous-Flow Rotor, Titanium, Large Pellet Core. Includes Large Pellet continuous-flow core (pellet size 800 mL), standard-flow rotating seal assembly, and tool kit. Bracket kit required for use with Avanti J Series centrifuges, and pump system required for all applications.

| Max. RPM | Max. g | k Factor | Rotor Capacity |
|----------|--------|----------|----------------|
| 20 000 | 39 900 | 293 | 1 250 mL |

Bracket Kits for use with Avanti J-Series centrifuges

No. 363843. Bracket Kit, for use with Avanti J-25 Series and Avanti J-30I centrifuges, and standard Cole-Parmer size-16 tubing (6.4 mm, 1/4-in. O.D.). For other size tubing, see optional kits below.

No. 366431. Bracket Kit, for use with Avanti J-26 XP Series centrifuges, and standard Cole-Parmer size-16 tubing (6.4 mm, 1/4-in. O.D.). For other size tubing, see optional kits below.

No. 363844. Size-14 Tubing Adapter Kit, for use with Cole-Parmer size-14 tubing (4.8 mm, 3/16 in.). Order in addition to one of above Bracket Kits.

No. 363845. Size-15 Tubing Adapter Kit, for use with Cole-Parmer size-15 tubing (9.5 mm, 3/8 in.). Order in addition to one of above Bracket Kits.

Recommended Pumps

The chosen pump must meet the following requirements: (a) has a continuously adjustable flow rate from 6 to 100 mL/min; (b) has a flow rate controllable to within ±1.5%; (c) has a flow rate independent of back pressure up to 40 psi; and (d) has pulsation less than 5% of flow rate.

We recommend Cole-Parmer Masterflex® L/S® Standard Digital Pump E-77921-00 (115 VAC), or L/S Standard Digital Pump E-77921-07 (230 VAC). These are not available from Beckman Coulter, but may be ordered direct from Cole-Parmer (625 East Bunker Court, Vernon Hills, Illinois 60061-1844 USA, Phone 847-549-7600, Fax 847-549-7676, TDD hotline: 800-833-7400, E-mail: info@coleparmer.com). Contact Cole-Parmer directly to receive current ordering information for these or comparable pumps.

These pumps include: Easy-Load® pump head model E-07518-12 (accepts L/S 15 and L/S 24 tubing), 10 ft. (3 m) of Tygon® LFL L/S 24 tubing model E-06429-24 (flow range of 28 to 1700 mL/min), and 10 to 600 rpm standard digital drive model E-07523-20 (115 VAC) or E-07523-27 (230 VAC).

* Masterflex, L/S, and Easy-Load are registered trademarks of Cole-Parmer Instrument Company.

† Tygon is a registered trademark of Norton Company.

Zonal and Reorienting Gradient Rotors

No. 354006. JCF-Z Zonal Rotor, Titanium.

Includes Zonal core, standard-flow rotating seal assembly, and tool kit. Bracket kit required for use with Avanti J Series centrifuges, and pump system required for all applications.

| Max. RPM | Max. g | k Factor | Rotor Capacity |
|----------|--------|----------|----------------|
| 20 000 | 39 900 | 710 | 1 990 mL |

No. 354005. JCF-Z Reorienting Gradient Rotor, Titanium.

Includes reorienting gradient core, sample transfer assembly, and tool kit. Bracket kit required for use with Avanti J Series centrifuges, and pump system required for all applications.

| Max. RPM | Max. g | k Factor | Rotor Capacity |
|----------|--------|----------|----------------|
| 20 000 | 39 900 | 779 | 1 750 mL |

Interchangeable Cores and Accessories

- 335130 Continuous-flow Core, Standard
- 350641 Continuous-flow Core, Large-Pellet
- 350601 Continuous-flow Core, Small-Pellet
- 335141 Zonal Core
- 343348 Zonal Keylock Switch for J2-21
- 350585 Reorienting Gradient Core and Sample Transfer Assembly
- 335142 Standard-flow, Rotating Seal Assembly required for Zonal- and Continuous-flow Operation
- 335134 High-flow Seal Assembly Kit: permits processing up to 100 liters/hour in Continuous-flow Core

JCF-Z-Rotor Replacement Parts

- 335144 Rotating Seal, Carbon-graphite
- 812715 O-ring for JCF-Z Rotor Plug (Min. order 12)
- 815473 O-ring for JCF-Z Rotor Lid Stem, 3/8" O.D. (Min. order 6)
- 824412 O-ring for JCF-Z Rotating Seal, 3/4" O.D. (Min. order 6)
- 854519 O-ring for bottom of JCF-Z-Rotor Bowl (Min. order 6)
- 366190 Bearing, Stainless Steel
- 870655 O-ring for JCF-Z Rotating Seal, .502 O.D. (Min. order 6)
- 870688 O-ring for JCF-Z Rotor Lid, 7.188 O.D.
- 335143 Tool Kit

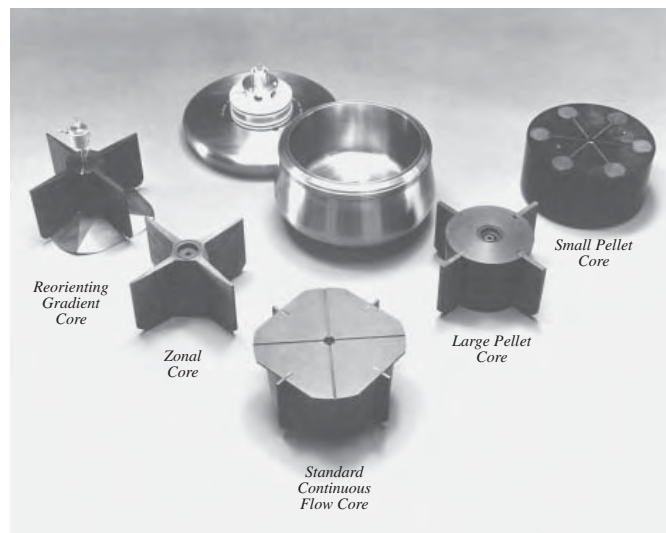

For use in Avanti® J Series centrifuges (except Avanti J-E).

Many of the parts on this list are pictured for easy identification.

Supply List

- 336079 Bearing Housing (anodized aluminum)
- 366190 Bearing (stainless steel)
- 336285 Bearing Spacer (stainless steel)
- 350585 Reorienting Gradient Core and Sample Transfer Assembly
- 335136 Feed Fitting, High-flow (stainless steel)*
- 335146 Feed Fitting, Standard-flow (stainless steel)*
- 344108 Fitting Retaining Clamp (Noryl†)
- 338672 Housing, High-flow Stationary Seal (stainless steel)
- 336080 Housing, Standard-flow Stationary Seal (stainless steel)
- 336284 Mount, Rotating Seal (stainless steel)
- 870526 O-ring, Continuous-flow Lid
- 817033 O-ring, (Viton‡), Continuous-flow Lid
- 824412 O-ring, Rotating Seal
- 824464 O-ring, Seal Housing Feed Fitting
- 870656 O-ring, (Viton‡), Transfer Tube Assembly
- 870315 O-ring, Zonal Lid
- 870689 Retaining Ring (stainless steel)
- 335120 Sample Transfer Tube, Standard-flow Seal Assembly (stainless steel)
- 335132 Sample Transfer Tube, High-flow Seal Assembly (stainless steel)
- 336286 Scavenger Drain Tube (stainless steel)
- 804063 Screw (stainless steel)
- 870690 Screw (stainless steel)
- 335133 Seal Assembly, High-flow
- 335148 Silicone Vacuum Grease
- 339555 Solution 555™ Rotor Cleaning Concentrate
- 306812 Spinkote™ Lubricant
- 870654 Spring (stainless steel)
- 335145 Stationary Seal (ceramic)
- 336403 Stoppers for Tubing Lines (#1, one-hole)
- 306653 Tygon** Tubing
- 878279 Washer, Flat (nylon)
- 853118 Washer, High-flow Seal
- 853391 Washer, Flat (stainless steel)
- 870658 Washer, Spring (spring steel)

* Use Loctite grade "T" primer and #35 retaining compound to bond fitting to seal housing.
 Loctite is a registered trademark of Loctite Corporation.
 † Noryl is a registered trademark of GE Plastics.
 ‡ Viton is a registered trademark of E. I. Du Pont de Nemours & Company.
 ** Tygon is a registered trademark of Norton Company.

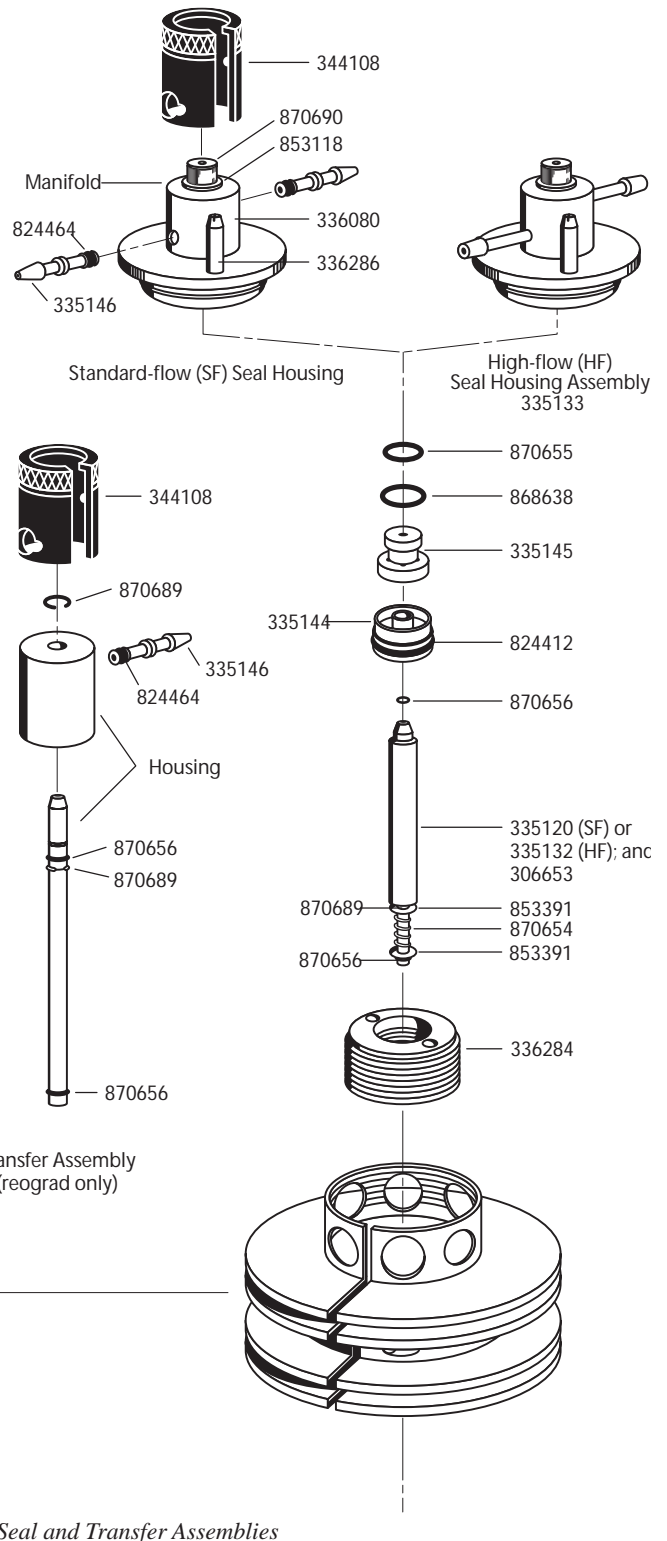
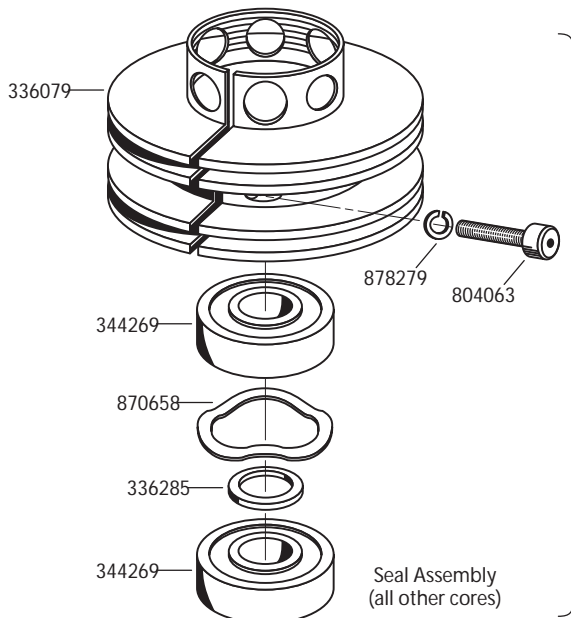

Seal and Transfer Assemblies

Note: Standard-flow Manifold consists of part numbers 870690, 853118, 336080, 870655, 868638, and 335145. High-flow Manifold is part of High-flow Seal Housing Assembly, which consists of part numbers 870690, 853118, 338672, 2 x 335136, and 336286.

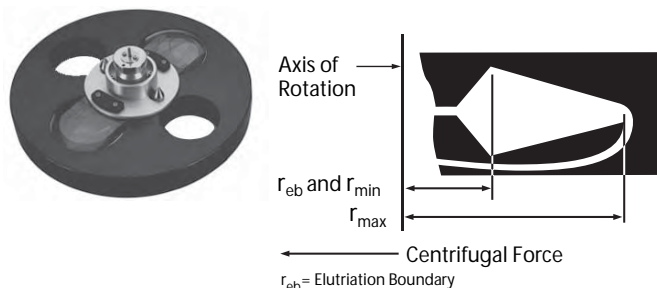

Elutriator Rotor

For use in Avanti® J-26 XP Series and J6-MI centrifuges equipped with viewport door and strobe assembly.

| Max. RPM | Max. g | Maximum Volume | Elutriation Boundary |
|----------|--------|----------------|----------------------|
| 5 000 | 4 700 | 40 mL | 86 mm (2,410 g) |

For use in Avanti® J-26 XP Series and J6-MI centrifuges.**

No. 356900. JE-5.0 Elutriator Rotor Assembly. Includes bypass chamber and supplies, and features a quick-release assembly which can be autoclaved for sterile operation. Order elutriation chamber(s) separately. (For complete Elutriation System, a number of components are necessary. See *How to Order* below.)

Elutriation Chamber

| Description | Part No. | Max. Cells Recovered per Run | Minimum Cells Required for Loading per Fraction | Max Elutriated Buffer Volume |
|-------------|----------|------------------------------|---|------------------------------|
| 40-mL | 356940 | 10 ¹⁰ | 10 ⁷ | 1000 mL |
| 5-mL | 356943 | 10 ¹⁰ | 10 ⁷ | 1000 mL |
| Sanderson | 356945 | 10 ¹⁰ | 10 ⁵ | 1000 mL |

How to Order

For a complete Beckman Coulter Elutriation System, the following components are required:

1. An Elutriator Rotor Assembly
2. An Elutriation Chamber
3. An Elutriation Centrifuge equipped with viewport door and strobe assembly.

Beckman Coulter Avanti J-26 XP Series and J6-MI centrifuges can be ordered as Elutriation Centrifuges fully equipped with the appropriate door and strobe assembly. See Section 1 for ordering information. Existing Beckman Coulter 6000-rpm centrifuges can also be adapted for elutriation. To do so, refer to the section below.

Also necessary but not available from Beckman Coulter is a pump that meets the following requirements: (a) has continuously adjustable flow rate from 6 to 100 mL/min; (b) has flow rate controllable to within ± 1.5%; (c) has flow rate independent of back pressure up to 40 psi; and (d) has pulsation less than 5% of flow rate. Recommended pumps are listed below.

To Upgrade an Existing Beckman Coulter Centrifuge

For Avanti J-26 XP Series, order the appropriate kit listed below (order only one kit):

No. 366562. 50/60 Hz. For use with Avanti J-26 XP. Kit includes Strobe Lamp/Control Assembly and Door Assembly with Viewport.

No. 366563. 50/60 Hz. For use with Avanti J-26 XPI. Kit includes Strobe Lamp/Control Assembly and Door Assembly with Viewport.

For J6-MI, order BOTH of the kits below:

No. 358354. 50/60 Hz. Strobe Lamp and Control Assembly for use with current model microprocessor-controlled J6-MI centrifuges. Requires door assembly sold below.

No. 360345. 50/60 Hz. Door Assembly with Viewport for use with current model microprocessor-controlled J6-MI centrifuges. Requires strobe lamp and control assembly sold above.

Recommended Pump (not supplied by Beckman Coulter)

We recommend the Cole-Parmer Masterflex® Digital Drive Pump System. These are not available from Beckman Coulter, but may be ordered directly from Cole-Parmer (625 East Bunker Court, Vernon Hills, Illinois 60061-1844 USA, Phone 847-549-7600, Fax 847-549-7676, TDD hotline: 800-833-7400, E-mail: info@coleparmer.com). Contact Cole-Parmer directly to receive current ordering information for these or comparable pumps.

A complete pump consists of one each of the following components:

1. Easy-Load® pump head (stainless steel)
2. Tygon† L/S* 16 tubing standard drive (10 to 600 rpm, 115 VAC or 230 VAC)

* Masterflex, Easy-Load, and L/S are registered trademarks of Cole-Parmer Instrument Company.
† Tygon is a registered trademark of Norton Company.

Supplies

| | |
|--------|--|
| 335148 | Silicone Vacuum Grease, 1 oz |
| 339555 | Solution 555™ Cleaning Concentrate, 1 qt |
| 306812 | Spinkote™ Lubricant (for rotor/shaft interface), 2 oz |
| 357520 | Tubing, Tygon 1/8-in. (I.D.) × 1/4-in. (O.D.) |
| 357580 | Tubing, Silicone 3/16-in. (I.D.) × 5/16-in. (O.D.) (for rotating seal-assembly connection) |

Tools

| | |
|--------|---|
| 927784 | Pliers for Retaining Clip (bearing removal) |
| 016223 | Wrench, 1/8-in. Hex Driver |
| 927766 | Wrench, 5/16-in. Hex T-handle |
| 029840 | Wrench, 5/32-in. Hex Driver |
| 001884 | Wrench, 5/64-in. Hex Driver |
| 817305 | Wrench, 9/64-in. Hex Angle |

** When properly equipped for elutriation.



1

Replacement Parts

- 358291 Quick-release Seal Assembly 5.0 with counterbalance
- 366922 Anchor Cable Assembly for Avanti J-26 XP Series centrifuge
- 358182 Anchor Cable Assembly for J6-MI centrifuge
- 355161 Ball Bearing, S.C.D.
- 356014 Cable Retainer
- 356940 Chamber, Large (40-mL), "A"
- 356941 Chamber, Large (40-mL), "B"
- 356943 Chamber, Standard (5-mL), "A"
- 356944 Chamber, Standard (5-mL), "B"
- 356945 Chamber, Sanderson (5-mL), "A"
- 356946 Chamber, Sanderson (5-mL), "B"
- 849660 Chamber Mounting Nut
- 356917 Chamber Pad
- 356907 Chamber Gasket, 40-mL
- 356935 Chamber Gasket, 4-mL
- 359399 Chamber Gasket, Sanderson, 4-mL
- 356930 Chamber Mount
- 356921 Chamber Tube (solid)
- 356942 Counterbalance
- 927768 Fitting, Inlet Line (to seal assembly), 3/16 in. I.D.
- 000148 Fuse, Strobe, 1.0 A-TD 250 VAC
- 870671 Glass Plate for Lapping Seal (4 x 5 in.)
- 356912 Housing, Bearing
- 356911 Housing, Seal
- 870655 O-ring, Small, Seal Housing
- 011519 O-ring, Small, Bearing Shaft
- 868638 O-ring, Large, Seal Housing
- 853984 O-ring, Center Tube
- 853696 O-ring, Retaining, Center Tube
- 010426 O-ring, Transfer Tube
- 356910 Plate, Chamber/Seal Support
- 340148 Pressure Gauge Assembly
- 347549 Reflector, rpm
- 878681 Retaining Clip, Bearing Assembly
- 356915 Retaining Plate, Transfer Tube
- 927286 Retaining Ring, Internal
- 335213 Sample Reservoir, 30-mL
- 335197 Sample Reservoir, 30-mL
- 803993 Screw, Cap (support plate to seal housing)
- 927569 Screw, Cap (retaining plate)
- 841717 Screw, Chamber Mounting
- 824905 Screw, Housing
- 929279 Screw, Shoulder (chamber assembly)
- 347526 Seal, Rotating, Black
- 335145 Seal, Stationary, White
- 347543 Syringe Assembly
- 356913 Shaft (bearing)
- 357459 Spacer (spring/seal)
- 340145 Spring (seal assembly)
- 356920 Tube, Long
- 356919 Tube, Short
- 356914 Tube, Transfer
- 870669 Valve, Stopcock (3-way)
- 021623 Washer, Flat (bearing housing to support plate)
- 887438 Washer, Flat (bearing housing to support plate)
- 889303 Washer, Flat (seal housing)
- 927730 Washer, Spring (retaining plate)
- 927731 Washer, Spring (support plate to seal housing)
- 852685 Washer, Spring (bearing assembly, 3 required)
- 878475 "Y" Hose Fitting
- 347978 Flash Tube

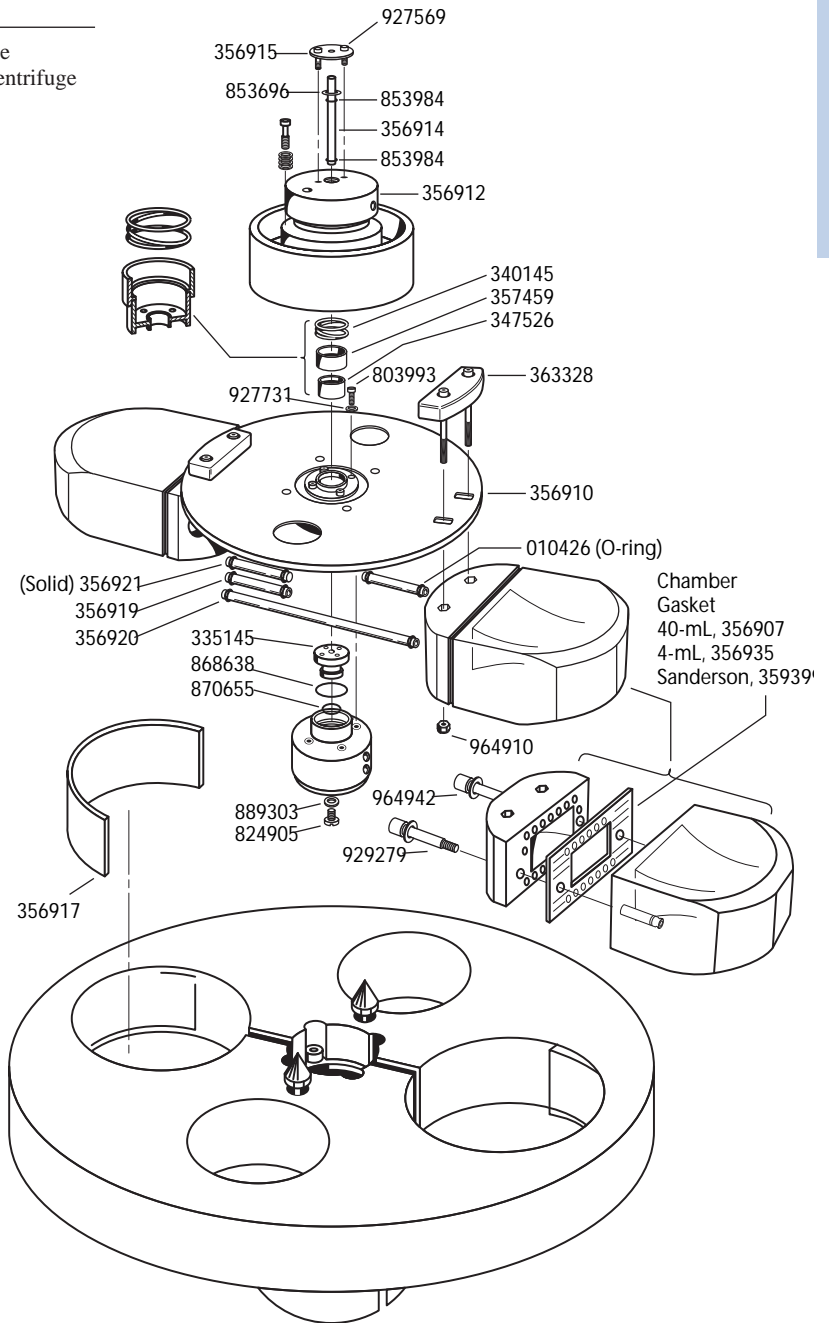

Exploded View of JE-5.0 Parts with Part Numbers

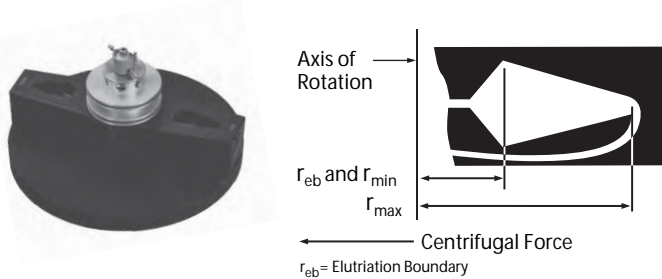

Elutriator Rotor

| Max. RPM | Max. g | Maximum Volume | Elutriation Boundary |
|----------|--------|----------------|----------------------|
| 6 000 | 5 080 | 5 mL | 86 mm (3,470 g) |

For use in Avanti® J-25 Series and J-30I centrifuges equipped with viewport door and strobe assembly.

No. 347514. JE-6B Elutriator Rotor Assembly. Includes bypass chamber and supplies. For use in Avanti J-25 Series and J-30I Elutriation Centrifuges and earlier J2 Series centrifuges already equipped with Elutriation Accessories. Order elutriation chamber(s) separately. (For complete Elutriation System, a number of components are necessary. See *How to Order* below.)

Elutriation Chamber

| Description | Part No. | Max. Cells Recovered per Run | Minimum Cells Required for Loading per Fraction | Max Elutriated Buffer Volume |
|-------------|----------|------------------------------|---|------------------------------|
| 5-mL | 347986 | 10 ⁹ | 10 ⁷ | 100 mL |
| Sanderson | 347985 | 10 ⁹ | 10 ⁵ | 100 mL |

How to Order

For a complete Beckman Coulter Elutriation System, the following components are required:

1. An Elutriator Rotor Assembly
2. An Elutriation Chamber
3. An Elutriation Centrifuge equipped with viewport door and strobe assembly.

Beckman Coulter Avanti J-25 Series and J-30I Centrifuges can be ordered as Elutriation Centrifuges fully equipped with the appropriate door and strobe assembly. Existing Beckman Coulter Avanti J-25 and Avanti J-30I centrifuges can also be adapted for elutriation. To do so, order the appropriate assembly below.

Also necessary but not available from Beckman Coulter is a pump that meets the following requirements: (a) has continuously adjustable flow rate from 6 to 100 mL/min; (b) has flow rate controllable to within ± 1.5%; (c) has flow rate independent of back pressure up to 40 psi; and (d) has pulsation less than 5% of flow rate. Recommended pumps are listed below.

To Upgrade an Existing Beckman Coulter Centrifuge

For Beckman Coulter Avanti J-25 Series and J-30I, order the appropriate kit listed below (order only one kit):

No. 363840. 50/60 Hz. For use with Avanti J-25. Kit includes Strobe Lamp/Control Assembly and Door Assembly with Viewport.

No. 363841. 50/60 Hz. For use with Avanti J-25I and J-30I. Kit includes Strobe Lamp/Control Assembly and Door Assembly with Viewport.

Recommended Pump (not supplied by Beckman Coulter)

We recommend the Cole-Parmer Masterflex Digital Pump Drive System. These are not available from Beckman Coulter, but may be ordered direct from Cole-Parmer (625 East Bunker Court, Vernon Hills, Illinois 60061-1844 USA, Phone 847-549-7600, Fax 847-549-7676, TDD hotline: 800-833-7400, E-mail: info@coleparmer.com). Contact Cole-Parmer directly to receive current ordering information for these or comparable pumps.

* Masterflex, Easy-Load, and L/S are registered trademarks of Cole-Parmer Instrument Company.
† Tygon is a registered trademark of Norton Company.

A complete pump consists of one each of the following components:

1. Easy-Load® pump head model E-07518-10 (stainless steel)
2. Tygon† L/S* 14 tubing model E-96420-14 standard digital drive (10 to 600 rpm) model E-07523-20 (115 VAC) or E-07523-27 (230 VAC).

Replacement Parts

| | |
|--------|---|
| 335145 | Stationary Seal |
| 355161 | Bearing Assembly Ball Bearings (2) |
| 347524 | Bearing Assembly Spacer |
| 340145 | Bearing Assembly Spring Washer |
| 347985 | Chamber, Sanderson (not including O-rings) |
| 347986 | Chamber, Standard (not including O-rings) |
| 340149 | Chamber Gasket (Sanderson) |
| 340144 | Chamber Gasket (Standard) |
| 010426 | Chamber O-rings (8) |
| 347528 | Chamber Plugs (2) |
| 347912 | Chamber Screws (2) |
| 347919 | Photoelectric Detector |
| 347549 | Reflecting Label |
| 347526 | Rotating Seal |
| 335146 | Seal Housing Feed Fitting |
| 824464 | Seal Housing Feed Fitting O-rings (2) |
| 344108 | Seal Housing Plastic Feed Fitting Retainer Clamps (2) |
| 336284 | Seal Mount |
| 815473 | Shaft O-ring (lowest) |
| 011519 | Shaft O-ring (upper) |
| 336285 | Spacer |
| 347918 | Strobe Lamp Assembly |
| 869306 | Foot Pads for Strobe Control (4) |
| 000148 | Strobe Fuse |
| 347978 | Strobe Lamp Bulb |
| 347517 | Transfer Tube |
| 853984 | Transfer Tube O-ring |
| 347520 | Transfer Tube Screw |
| 878238 | Transfer Tube Screw O-rings, Larger |
| 878239 | Transfer Tube Screw O-rings, Smaller |

Replacement Parts for Previous Model JE-6 Rotor

| | |
|--------|--|
| 010426 | O-ring for Separation Chamber and Bypass Chamber |
| 335196 | Bypass Chamber |
| 335205 | Separation Chamber |
| 335206 | Sanderson-type Chamber |
| 340144 | Gasket for Separation Chamber |
| 340149 | Gasket for Sanderson-type Chamber |
| 347912 | Screw for Separation Chamber |

Supplies and Tools

- 001311 Allen Wrench, 3/16 in.
- 340144 Chamber Gasket, Standard
- 340149 Chamber Gasket, Sanderson
- 870671 Glass Plate for resurfacing (lapping) rotating seals
- 001885 Hex Driver Wrench, 3/32 in.
- 335213 Sample Reservoir, 30-mL (including needles)
- 335197 Sample Reservoir, 75-mL (including needles)
- 005898 Screwdriver

- 335148 Silicone Vacuum Grease, 1 oz
- 339555 Solution 555™ Cleaning Solution, 1 qt.
- 870666 Spanner Wrench
- 306812 Spinkote™ Lubricant, 2 oz
- 306956 Tubing, Silastic® 7.6 m (25 ft.)
- 306833 Tubing, Tygon† 3.0 m (10 ft.)

* A registered trademark of Dow Corning Corporation.
† A registered trademark of Norton Company.

For more information on elutriation, order Bulletin SB-574.

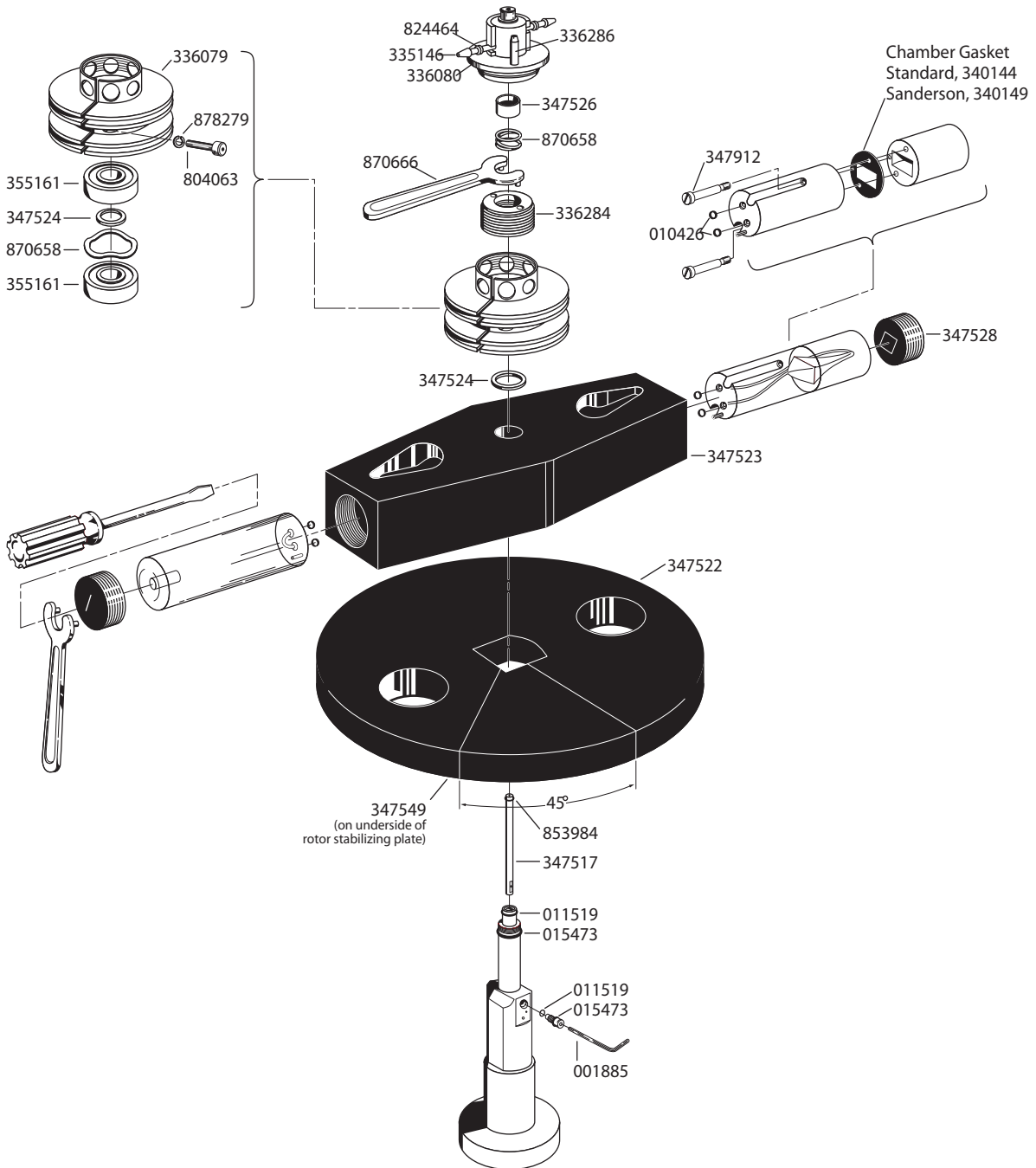

Tubes and Bottles

Tubes and Bottles for Every Application

No single tube design or material will meet all application requirements. A number of factors should be considered when a supply of tubes is ordered: the particular technique to be used, the nature of the sample and any solvent or gradient media, the desirability of reusing the tubes, and certain convenience factors. The properties listed below provide a guide for anyone involved in the tube selection process.

- **Strength and Flexibility**, to resist permanent deformation even when run in fixed angle rotors without tube caps
- **Chemical Resistance** to a wide range of bases, acids, and solvents
- **Transparency**, to permit a clear view of fractions and bands after centrifugation
- **Thin** enough to be sliced or punctured after centrifugation for fraction collection
- **Impermeable to Water**, to prevent aqueous solutions from permeating the tube wall and reaching the rotor cavity
- **Surface Properties** that prevent the adherence of nucleic acids and proteins
- **Temperature Tolerance** throughout a wide range of operating temperatures, without deforming at high temperatures or cracking when used close to 0°C
- **Autoclavable**, for convenient sterilization and reuse
- **Contaminant-free**, to avoid leaching extraneous materials into the sample, especially materials visible in the sensitive 240-280 nm range
- **Odor-free**, for pleasant handling

The full line of Beckman Coulter tubes includes a number of tube materials, each with its own distinct combination of properties to meet a variety of application requirements. Available are transparent, translucent, and opaque tubes; tubes that can be sliced or punctured; tubes that can be sterilized and reused; and tubes that are resistant to a variety of chemical compounds.

Tubes and Bottles

Tube Selection Considerations

Compatibility of Tube Material with Solvents and Sample

The chemical compatibility of the tube materials with the gradient-forming medium or other solvent is a prime consideration. Neutral sucrose and salt solutions cause no problem. But alkaline solutions, such as those frequently used for the separation of single-stranded forms of DNA, cannot be used in Ultra-Clear™ tubes or polycarbonate tubes and bottles. Sometimes DMSO is used in preparation of sucrose gradients for sedimentation of denatured RNA. Polycarbonate and Ultra-Clear tubes are incompatible with DMSO, so polyallomer tubes should be used.

The last column of the “Quick Reference Chart to Tube Materials and Their Properties” on page 2-4 gives some guidelines to the chemical resistances of the various tube materials. It must be emphasized, however, that other conditions of centrifugation (*g*-force, duration of run, etc.) have considerable effect on how well a tube material will withstand a particular solvent. Beckman Coulter publication IN-175, “Chemical Resistances for Beckman Coulter Centrifugation Products” (found on the Beckman Coulter web site at <http://www.beckman.com/resourcecenter/labresources/centrifuges/chemres.asp>) provides more detailed information about the chemical resistances of the various tube materials. The wisest course is to test any questionable combination under operating conditions before making the actual run.

The type of sample, in some cases, will affect selection of a specific tube material. DNA, in its denatured or single-stranded form, will adhere to the surface of some tube materials. Polyallomer would be the best choice. (Most of this work is done in highly alkaline media which are incompatible with polycarbonate.)

Lipoprotein separations are most often done in Ultra-Clear tubes because they are clear and sliceable; these properties simplify fraction location and recovery by tube slicing. When small lipoprotein samples are to be recovered by a fractionating device and clear tubes are desirable, there are alternatives: cellulose propionate, polycarbonate, and Ultra-Clear tubes.

Hazardous materials, either pathogenic or radioactive, should be centrifuged with extreme care. All possible precautions must be taken to avoid leakage of the sample into the rotor cavity during centrifugation.

To determine the optimum tube material for your specific sample and gradient medium, refer to the quick reference chart on page 2-4.

Gradient Formation and Fractionation

When choosing a tube for a density gradient run, some thought should be given to gradient formation and fractionation. If the bands or zones formed during centrifugation are indistinct, they may not be visible through a translucent material such as polyallomer. If optimum band visualization is important, Ultra-Clear tubes or tubes of polycarbonate or cellulose propionate should be used. Whenever collection of bands or zones must be

done by puncturing the tube or slicing, a thin, flexible tube wall is required. Ultra-Clear or polyallomer tubes should be used, depending on the need for transparency.

As there are currently no wettable plastic centrifuge tubes available, gradients should be loaded into plastic tubes from the bottom up to avoid mixing.

High Temperature Centrifugation

Although modern centrifuges and rotors can operate at temperatures as high as 45°C, one cannot assume that every tube can be safely run over 25°C. Stainless steel and glass are the only materials which will not experience some deformation when subjected to high temperatures and long centrifugation times. Plastic tubes undergo some degree of softening at temperatures higher than 25°C. Whether or not this will cause permanent deformation is not a question of temperature alone. The centrifugal force field used, the duration of the centrifugation, the type of rotor, and even the tube angle all have an effect.

It's obviously impossible to give exact temperature limits for plastic tubes when so many other variables are involved. The safest policy is to pretest the tubes under the actual experimental conditions, but with water, rather than a valuable sample.

Tube Sizes

Tube sizes as indicated in the following charts are nominal sizes, and may vary somewhat from actual filling capacities. If a thickwall tube is run uncapped, the maximum filling volume will depend on the tube angle of the rotor to be used. See appropriate rotor instruction manuals for maximum filling levels of tubes.

Tube Cleaning, Sterilization, and Reuse

If tubes are to be reused, special care must be taken during cleaning and sterilization. All tubes can be washed by hand with a mild detergent such as Solution 555™ diluted 5-to-1 or 10-to-1 with water. This is particularly important for polycarbonate tubes and bottles which should not be exposed to a detergent with a pH higher than 8. Tubes and bottles should not be washed in commercial dishwashers as the detergents and high temperatures are too harsh. Solvents such as alcohol or acetone react unfavorably with many tube materials. If an organic solvent must be used in the cleaning procedure, consult bulletin IN-175 for a table of tube material/solvent compatibilities (or review the same document on the Beckman Coulter web site at <http://www.beckman.com/resourcecenter/labresources/centrifuges/chemres.asp>).

The method chosen for sterilization has direct bearing on the number of reuses one can expect from a tube. Tubes and bottles of polyallomer, polyethylene, and glass can all be autoclaved, although in general, cold sterilization methods are not as harsh as autoclaving. Cold sterilization is recommended for both polycarbonate and Ultra-Clear.

Tubes and Bottles

If maximum reuse is a major consideration, either polyallomer (preferably thickwall) or polycarbonate tubes and bottles should be selected, and cold sterilization methods used. If these tubes are run completely filled in swinging bucket rotors, most of them can be reused a number of times. Chances of permanent deformation will be greater whenever the tubes are run in fixed angle rotors, without caps, and/or partially filled. All of these conditions tend to stress the centripetal edge of the tube unduly. All tubes that have been used or autoclaved previously must be individually examined for signs of deformation or cracking before using them again.

Tube Closures

When other considerations have been resolved, convenience may be a deciding factor. Without a doubt, the most convenient tube closure is none at all; none are required for tubes run in swinging bucket rotors.

For tubes run in fixed angle rotors, alternatives to the standard tube cap assemblies are available. Bottles have three-piece cap assemblies which are easier to use than the more complex tube cap assemblies. Polycarbonate bottles are available for general-purpose fixed angle rotors, and are used frequently for differential centrifugation where band recovery is not a problem. Thickwall tubes can be run in all fixed angle rotors without caps, provided they are partially filled. (Refer to rotor manuals for more information on fill volumes.)

When closed tubes are required, Beckman Coulter offers some innovative and convenient options.

A Quick-Reference Chart to Tube Materials and Their Properties

| Property | Thinwall Polyallomer | Thickwall Polyallomer | Ultra-Clear™ | Polycarbonate | Polypropylene | Polyethylene | Cellulose Propionate |
|--|----------------------|-----------------------|--------------|---------------|---------------|-------------------------|----------------------|
| Optical | transparent | translucent | transparent | transparent | transparent | transparent/translucent | transparent |
| Autoclaveable | yes | yes | no | no | yes | no | no |
| Puncturable | yes | no | yes | no | no | yes | no |
| Sliceable | yes | no* | yes | no* | no | no | no* |
| Reusable | no | yes | no | yes | yes | yes | no |
| Acids (dilute or weak) | S | S | S | S | S | S | S |
| Acids (strong) | U | S | U | U | S | S | U |
| Alcohols (aliphatic) | U | S | U | U | S | S | U |
| Aldehydes | M | M | S | M | M | S | U |
| Bases | S | S | U | U | S | S | U |
| Esters | U | M | U | U | M | S | M |
| Hydrocarbons (aliphatic) | U | M | U | U | S | U | S |
| Hydrocarbons (aromatic and halogenated) | U | U | U | U | M | M | S |
| Ketones | U | M | U | U | M | M | U |
| Oxidizing Agents (strong) | U | U | U | M | M | M | M |
| Salts | S | S | M | M | S | S | S |

S = satisfactory resistance M = marginal resistance U = unsatisfactory resistance

* Polyallomer, polycarbonate, and cellulose propionate tubes with diameters of 5 to 13 mm may be sliced using the CentriTube Slicer (part number 347960) and appropriate adapter plate.

Note: This information has been consolidated from a number of sources and is provided only as a guide to the selection of tube materials. Soak tests at 1 g (at 20°C) established the data for most of the materials; reactions may vary under the stress of centrifugation, or with extended contact or temperature variations. To prevent failure and loss of valuable sample, ALWAYS TEST SOLUTIONS UNDER OPERATING CONDITIONS BEFORE USE.

Warning: Do not use flammable substances in or near an operating centrifuge.

Tubes and Bottles

General Filling and Sealing Requirements for Tubes and Bottles

| | Tube or Bottle | Swinging-Bucket Rotors | Fixed-Angle Rotors |
|------------------------|-------------------|---|---|
| Polyallomer | Thinwall tubes | Within 2 to 3 mm of top | Full with cap |
| | Thickwall tubes | At least 1/2 full | 1/2 full to max. capless level or full with cap |
| | Quick-Seal tubes | Full and heat-sealed | Full and heat-sealed |
| | Bottles | Min. to max. (see rotor manual) with screw-on cap or cap assembly | 1/2 full to max. (see rotor manual) with screw-on cap assembly |
| Ultra-Clear | Open-top tubes | Within 2 to 3 mm of top | Full with cap |
| | Quick-Seal tubes | Not used | Full and heat-sealed |
| Polycarbonate | Thickwall tubes | At least 1/2 full | 1/2 full capless level or full with cap or cap assembly |
| | Bottles | At least 1/2 full | Min. to max. (see rotor manual) with screw-on cap or cap assembly |
| Stainless Steel | Tubes | Any level | Any level with cap or cap assembly |
| Polypropylene | Tubes and bottles | At least 1/2 full | 1/2 to max. capless level or full with cap or cap assembly |
| Polyethylene | Tubes | At least 1/2 full | 1/2 to max. capless level or full with cap or cap assembly |
| Teflon | Tubes and bottles | At least 1/2 full | 1/2 full to max. capless level or full with cap |
| Radel | Container | At least 1/2 full | N/A |

Tubes and Bottles

High-Performance and High-Capacity Bottles

| Nominal Capacity | Size mm | Material | Bottle & Cap Assy | Bottle with Screw Cap | Bottle Only | Insert Only | O-ring | Screw Cap Only |
|---------------------|-------------|----------|-------------------|-----------------------|--------------|--------------|--------------|----------------|
| 10 mL | 16 x 80 | PC | N.A. | 355672 | N.A. | N.A. | N.A. | N.A. |
| 10 mL | 16.1 x 81.1 | PA | N.A. | 364695 | N.A. | N.A. | N.A. | N.A. |
| 10 mL | 16.1 x 81.1 | T | N.A. | 364693 | N.A. | N.A. | N.A. | N.A. |
| 26.3 mL | 25 x 89 | PC | 355616 | N.A. | 340382 | 335258 | 870385 | 335259 |
| 30 mL | 25.3 x 92 | PA | 363073 | N.A. | N.A. | N.A. | N.A. | N.A. |
| 30 mL | 25.3 x 92 | PC | N.A. | 363070 | N.A. | N.A. | N.A. | N.A. |
| 40 mL | 29 x 104 | PC | N.A. | 355628 | N.A. | N.A. | N.A. | N.A. |
| 50 mL | 28.5 x 107 | T* | N.A. | 363076 | N.A. | N.A. | N.A. | N.A. |
| 50 mL | 29 x 104 | PA | 357001 361694 | 357003 | N.A. | 358627 | 870655 | 356284 |
| 50 mL | 29 x 104 | PC | 357000 361693 | 357002 | N.A. | 358627 | 961582 | N.A. |
| 70 mL | 38 x 102 | PC | 355620 | N.A. | 355655 | 334545 | 870384 | 334547 |
| 85 mL | 38 x 104 | PC | 363081 | N.A. | N.A. | N.A. | N.A. | N.A. |
| 85 mL | 38 x 104 | PP | N.A. | 364719 363082 | N.A. N.A. | N.A. N.A. | N.A. N.A. | N.A. N.A. |
| 100 mL | 38 x 102 | PP | 355624 | 355624 | 355626 | N.A. | 889633 | 355615 |
| 180 mL | 55 x 104 | PE | N.A. | 361245 | 961896 | N.A. | N.A. | N.A. |
| 230 mL | 62 x 141 | PA | 356989 | N.A. | 356988 | N.A. | N.A. | 344691 |
| 230 mL | 62 x 141 | PC | 356987 | N.A. | 356986 | N.A. | N.A. | 344691 |
| 250 mL | 62 x 120 | W PC | 356013 | N.A. | 358275 | N.A. | 927860 | 358977 |
| 250 mL | 62 x 122 | W PP | 356011 | N.A. | 358326 | N.A. | 927860 | 358977 |
| 250 mL round bottom | 62 x 136 | PC | N.A. | 355673 | N.A. | N.A. | N.A. | 356261 |
| 500 mL | 69 x 160 | W PC | 355605 | 355664 | 355649 | 334419 | 870411 | 356260 |
| 500 mL | 69 x 160 | W PP | 355607 | 355665 | 355650 | 334419 | 870411 | 356260 |
| 500 mL | 69 x 160 | PC | 361690 | N.A. | 355649 | N.A. | 927860 | 360954 |
| 500 mL | 69 x 160 | PP | 361691 | N.A. | 355650 | N.A. | 927860 | 360954 |
| 750 mL | 96 x 130 | PC | N.A. | 358299 | 358297 | N.A. | N.A. | 344693 |
| 750 mL | 96 x 130 | PP | N.A. | 356855 | 349815 | N.A. | N.A. | 344693 |
| 1000 mL | 95 x 191 | PC | 363676 | 355675 | 366751 | 970883 | 970884 | 344693 |
| 1000 mL | 95 x 191 | PP | 363678 | 355676 | 366752 | 970883 | 970884 | 344693 |
| 1250 mL | — | Radel† | 367883 | N.A. | 367895 | N.A. | 367886 | N.A. |

PA = Polyallomer PC = Polycarbonate PE = Polyethylene PP = Polypropylene T = Teflon C = Conical W = Wide-Mouth N.A. = Not Available

* With high-speed screw cap.

† A registered trademark of Union Carbide Corporation.



Tubes and Bottles

Adapters and Sleeves for Non-Beckman Coulter Tubes/Bottles*

| Rotor | Tube Vol. | Size mm | # of Places | Part Number | | mm | | | |
|-----------|--------------|--------------|-------------|-------------|---------------------|---------------|----------|--------|--------|
| JA-30.50 | 5 mL | 12 x 75 | 1 | 356970 | JA-10 | 5 mL | 12 x 75 | 10 | 356967 |
| | 7 mL | 13 x 100 | 1 | 356976 | | 7 mL | 13 x 100 | 9 | 356973 |
| JA-25.50 | 5 mL | 12 x 75 | 1 | 356970 | 15 mL | Conical | 5 | 356960 | |
| | 7 mL | 13 x 100 | 1 | 356976 | 15 mL | Round-bottom | 5 | 356994 | |
| JA-21 | 5 mL | 12 x 75 | 1 | 356972 | 50 mL | Conical | 1 | 356965 | |
| JA-20.1 | 5 mL | 12 x 75 | 1 | 356971 | 50 mL | Round-bottom | 1 | 356996 | |
| | 7 mL | 13 x 100 | 1 | 356977 | F10 BCI-6x500y | 3 L | 69 x 160 | 6 | 393033 |
| JA-20 | 5 mL | 12 x 75 | 1 | 356970 | 6 x 500 mL | 2.75 x 6.5 in | | | |
| | 7 mL | 13 x 100 | 1 | 356976 | JS-13.1 | 5 mL | 12 x 75 | 1 | 356970 |
| JA-18 | 5 mL | 12 x 75 | 3 | 356969 | 7 mL | 13 x 100 | 1 | 356976 | |
| | 7 mL | 13 x 100 | 3 | 356975 | JS-7.5 | 5 mL | 12 x 75 | 9 | 356968 |
| | 15 mL | Conical | 1 | 356962 | 7 mL | 13 x 100 | 8 | 356974 | |
| | 50 mL | Conical | 1 | 356963 | 15 mL | Conical | 4 | 356964 | |
| JA-17 | 5 mL | 12 x 75 | 1 | 356970 | 50 mL | Conical | 1 | 356966 | |
| | 7 mL | 13 x 100 | 1 | 356976 | JS-4.2 & JS-4.2A | 3 mL | Conical | 26 | 339100 |
| JA-14 | 5 mL | 12 x 75 | 9 | 356968 | 15 mL | Conical | 14 | 339102 | |
| | 7 mL | 13 x 100 | 8 | 356974 | 250 mL | Conical | | 349849 | |
| | 15 mL | Conical | 4 | 356964 | | | | | |
| | 15 mL | Round-bottom | 4 | 356995 | | | | | |
| | 50 mL | Conical | 1 | 356966 | | | | | |
| | 50 mL | Round-bottom | 1 | 356997 | | | | | |
| JA-10.500 | 5 mL | 12 x 75 | 10 | 356967 | | | | | |
| | 7 mL | 13 x 100 | 9 | 356973 | | | | | |
| | 15 mL | Conical | 5 | 356960 | | | | | |
| | 15 mL | Round-bottom | 5 | 356994 | | | | | |
| | 50 mL | Conical | 1 | 356965 | | | | | |
| 50 mL | Round-bottom | 1 | 356996 | | | | | | |

| Rotor | Tube Vol. | Size | # of Places | Part Number |
|-------|-----------|------|-------------|-------------|
|-------|-----------|------|-------------|-------------|

Adapters for Glass Tubes in Beckman Coulter Rotors*

| Rotor | Tube Volume | Tube Material | Adapter Part Number | Rotor | Tube Volume | Tube Material | Adapter Part Number |
|-------------|-------------|----------------------|---------------------|---------------------|-------------|---|---------------------|
| JA-30.50 | 15 mL | Corex, Pyrex† | 870329 | JS-13.1 | 30 mL | Corex | 870331 |
| | 30 mL | Corex | 870331 | | 15 mL | Corex, Pyrex | 870329 |
| JA-25.50 | 15 mL | Corex, Pyrex | 870329 | JS-7.5 | 150 mL | Corex | 339362 |
| | 30 mL | Corex | 870331 | | 30 mL | Corex | 356997/870331 |
| JA-20.1 | 15 mL | Pyrex | 342643 | | 15 mL | Corex, Pyrex | 356995 |
| JA-20/JA-17 | 15 mL | Corex, Pyrex | 870329 | JS-4.2 & JS-4.2A | 3 mL | Pyrex Conical | 339100 |
| | 30 mL | Corex | 870331 | | 15 mL | Corex, Pyrex, Corex & Pyrex Conical and Conical Graduated | 339102 |
| JA-18 | 15 mL | Corex, Pyrex | 870329/347539 | 30 mL | Corex | 341977 | |
| | 30 mL | Corex | 870331/347539 | 150 mL | Corex | 339108/ 339362 | |
| JA-14 | 150 mL | Corex | 339362 | | | | |
| | 30 mL | Corex | 356997/870331 | | | | |
| | 15 mL | Corex | 356995 | | | | |
| | 15 mL | Corex, Pyrex Conical | 356964 | | | | |
| JA-10.500 | 150 mL | Corex | 362750/339362 | | | | |
| | 30 mL | Corex | 356996/870331 | | | | |
| | 15 mL | Corex, Pyrex Conical | 356960 | | | | |
| JA-10 | 150 mL | Corex | 362750/339362 | | | | |
| | 30 mL | Corex | 356996/870331 | | | | |
| | 15 mL | Corex, Pyrex Conical | 356960 | | | | |

* Check with tube manufacturer for maximum allowable g-force.

† Corex and Pyrex are registered trademarks of Corning Glass Works, Inc.



Tubes and Bottles

Tubes and Bottles Used in High-Performance and High-Capacity Rotors

| Nominal Filling Capacity (mL) | Nominal Size (mm) | Inches | Part No. | Rotors |
|---|-------------------|--------------|------------------|---|
| Quick-Seal™ Polyallomer Tubes | | | | |
| 4.2 | 16 x 32 | 0.65 x 1.25 | 356562 | JS-24.15 |
| 8.0 | 16 x 58 | 0.65 x 2.25 | 344621 | JS-24.15 |
| 8.5 | 25 x 38 | 0.65 x 2.5 | 358652 (konical) | JS-24.38 |
| 10.0 | 16 x 67 | 0.65 x 2.5 | 344622 | JS-24.15 |
| 15.0 | 25 x 38 | 1 x 1.5 | 343664 | JS-24.38 |
| 23.0 | 25 x 76 | 1 x 1.5 | 358654 (konical) | JS-24.38 |
| 27.0 | 25 x 64 | 1 x 2.5 | 343665 | JS-24.38 |
| 33.0 | 25 x 83 | 1 x 3.25 | 344623 | JS-24.38 |
| 100.0 | 38 x 102 | 1.5 x 4.0 | 345776 | JA-18 |
| Quick-Seal Ultra-Clear™ Tubes | | | | |
| 100.0 | 38 x 102 | 1.5 x 4.0 | 345778 | JA-18 |
| Quick-Seal Bell-Top Tubes | | | | |
| 4.3 | 16 x 38 | 0.65 x 2.5 | 356562 | JS-24.15 |
| 6.3 | 16 x 45 | 0.65 x 1.8 | 345830 | JS-24.15 |
| 8.0 | 16 x 58 | 0.65 x 2.25 | 344621 | JS-24.15 |
| 8.5 | 25 x 38 | 0.65 x 2.5 | 358652 (konical) | JS-24.38 |
| 10.0 | 16 x 67 | 0.65 x 2.5 | 344622 | JS-24.15 |
| 15.0 | 25 x 38 | 1 x 1.5 | 343664 | JS-24.38 |
| 23.0 | 25 x 76 | 1 x 1.5 | 358155 (konical) | JS-24.38 |
| 27.0 | 25 x 64 | 1 x 2.5 | 343665 | JS-24.38 |
| 33.0 | 25 x 83 | 1 x 3.25 | 344623 | JS-24.38 |
| Open-Top Tubes, Polyallomer | | | | |
| 15.0 | 16 x 96 | 0.65 x 3.85 | 361707 | JS-24.15 |
| 25.0 | 25 x 76 | 1.0 x 3.0 | 358125 (konical) | JS-24.38 |
| 30.0 | 25 x 89 | 1.0 x 3.5 | 358126 (konical) | JS-24.38 |
| 38.5 | 25 x 89 | 1.0 x 3.5 | 326823 | JS-24.38 |
| Open-Top Tubes, Polyallomer, Thickwall | | | | |
| 4.0 | 13 x 64 | 0.5 x 2.5 | 355644 | JA-25.15 |
| 4.0 | 13 x 64 | 0.5 x 2.5 | 355645 | JA-25.15 |
| 10.0 | 16 x 76 | 0.65 x 3.0 | 355640 | JA-25.15, JA-21, JA-20.1, JS-5.2, JS-4.3, JS-4.2, JS-4.2A, JS-4.0, JS-3.0 |
| 12.5 | 16 x 95 | 0.625 x 3.75 | 361708 (konical) | JS-24.15 |
| 32.0 | 25 x 89 | 1.0 x 3.5 | 355642 | JS-24.38 |
| Open-Top Tubes, Polycarbonate | | | | |
| 15.0 | 18 x 100 | 0.725 x 4.0 | 342080 | JA-25.15, JA-20.1, JS-5.2, JS-4.3, JS-4.2A, JS-4.2, JS-4.0, JS-3.0 |
| 50.0 | 29 x 104 | 1.125 x 4 | 363647 | JA-30.50, JA-25.50, JA-20, JA-18, JA-17, JA-14, JLA-10.500, JA-10, JS-7.5, JS-5.2, JS-4.3, JS-4.2, JS-4.2A, JS-4.0, JS-3.0, F14 BCI-6x250y, F14 BCI-14x50cy |
| 1000.0 | 95 x 191 | 3.8 x 7.65 | 363676 | JLA-9.1000, JLA-8.1000 |
| Open-Top Tubes, Polycarbonate, Thickwall | | | | |
| 10.0 | 16 x 76 | 0.65 x 3.0 | 355630 | JA-25.15, JA-21, JA-20.1, JS-13.1, JS-5.2, JS-4.3, JS-4.2, JS-4.2A, JS-4.0, JS-3.0 |
| 32.0 | 25 x 89 | 1.0 x 3.5 | 355631 | JS-24.38 |
| Open-Top Tubes, Polyethylene | | | | |
| 15.0 | 18 x 100 | 0.725 x 4.0 | 342081 | JA-25.15, JA-20.1, JS-5.2, JS-4.3, JS-4.2, JS-4.2A, JS-4.0, JS-3.0 |

Tubes and Bottles

| Nominal Filling Capacity (mL) | Nominal Size (mm) | Inches | Part No. | Rotors |
|---|-------------------|--------------|--|--|
| Open-Top Tubes, Polypropylene | | | | |
| 15.0 | 18 x 100 | 0.725 x 4 | 342082 | JA-25.15, JA-20.1, JS-5.2, JS-4.3, JS-4.2, JS-4.2A, JS-4.0, JS-3.0 |
| 50.0 | 29 x 104 | 1.125 x 4 | 357007 | JA-30.50, JA-25.50, JA-18, JA-17, JA-14, JLA-10.500, JA-10, JS-7.5, JS-5.2, JS-4.3, JS-4.2, JS-4.2A, JS-4.0, JS-3.0, F14 BCI-6x250y, F14 BCI-14x50cy |
| 100.0 | 38 x 102 | 1.5 x 4 | 355626 | JS-5.2, JS-4.2, JS-4.2A, JS-4.0, JS-3.0 |
| 500.0 | 69 x 160 | 2.75 x 6.5 | 355650 | JS-5.2, JS-4.3, JS-4.2, JS-4.2A, JS-4.0, JS-3.0 |
| 1000.0 | 95 x 191 | 3.8 x 7.65 | 363678 | JLA-9.1000, JLA-8.1000 |
| Open-Top Tubes, Ultra-Clear™ | | | | |
| 15.0 | 16 x 96 | 0.65 x 3.8 | 361706 | JS-24.15 |
| 38.5 | 25 x 89 | 1.0 x 3.5 | 344058 | JS-24.38 |
| Tubes with Snap-On Caps, Polyallomer | | | | |
| 1.5 | 11 x 38 | 0.4 x 1.5 | 357448 - Natural | JA-30.50, JA-25.50, JA-20, JA-18.1, JA-18, JS-13.1, JS-5.2, JS-4.2, JS-4.2A, JS-4.0, JS-3.0 |
| 1.5 | 11 x 39 | 0.4 x 1.5 | 357444 - Orange | JS-4.2, JS-4.2A, JS-3.0 |
| 1.5 | 11 x 39 | 0.4 x 1.5 | 357445 - Yellow | JS-4.2, JS-4.2A, JS-3.0 |
| 1.5 | 11 x 39 | 0.4 x 1.5 | 357446 - Green | JS-4.2, JS-4.2A, JS-3.0 |
| 1.5 | 11 x 39 | 0.4 x 1.5 | 357447 - Blue | JS-4.2, JS-4.2A, JS-3.0 |
| Tubes with Snap-On Caps, Polycarbonate | | | | |
| 50.0 | 29 x 104 | 1.125 x 4 | 363664 | JS-30.50, JA-25.50, JA-20, JLS-16.250, JA-14, JLA-10.250, JA-10, JS-13.1, JS-7.5, JS-5.2, JS-4.3, JS-4.2, JS-4.2A, JS-4.0, JS-3.0, F14 BCI-6x250y, F14 BCI-14x50cy |
| Tubes with Snap-On Caps, Polypropylene | | | | |
| 1.5 | 11 x 38 | 0.4 x 1.5 | 356090 - Natural | JA-30.50, JA-25.50, JA-20, JA-18, JS-13.1, JS-5.2, JS-4.2, JS-4.2A, JS-4.0, JS-3.0 |
| 1.5 | 11 x 38 | 0.4 x 1.5 | 356091 - Blue | JA-20, JA-18, JS-13.1, JS-5.2, JS-4.2, JS-4.2A, JS-4.0, JS-3.0 |
| 1.5 | 11 x 38 | 0.4 x 1.5 | 356092 - Green | JA-20, JA-18, JS-13.1, JS-5.2, JS-4.2, JS-4.2A, JS-4.0, JS-3.0 |
| 1.5 | 11 x 38 | 0.4 x 1.5 | 356093 - Yellow | JA-20, JA-18, JS-13.1, JS-5.2, JS-4.2, JS-4.2A, JS-4.0, JS-3.0 |
| 1.5 | 11 x 38 | 0.4 x 1.5 | 356094 - Orange | JA-20, JA-18, JS-13.1, JS-5.2, JS-4.2, JS-4.2A, JS-4.0, JS-3.0 |
| 1.5 | 11 x 38 | 0.4 x 1.5 | 343169 - Natural (cap separate) | JA-18.1, JA-18, JS-5.2, JS-4.2, JS-4.2A, JS-4.0, JS-3.0 |
| 1.8 | 11 x 39 | 0.4 x 1.5 | 340196 - Natural | JA-20, JA-18.1, JA-18, JS-13.1, JS-5.2, JS-4.2, JS-4.2A, JS-4.0 |
| 50.0 | 29 x 103 | 1.125 x 4 | 357005 (cap separate) | JA-30.50, JA-25.50, JA-20, JA-17, JLA-16.250, JA-14, JLA-10.500, JA-10, JS-13.1, JS-7.5, JS-5.2, JS-4.2, JS-4.2A, JS-4.0, JS-3.0, F14 BCI-6x250y, F14 BCI-14x50cy |
| 500.0 | 69 x 160 | 2.75 x 6.5 | 361691 | JLA-10.500 |
| Conical Tubes | | | | |
| 8.5 | 25 x 38 | 0.65 x 2.5 | 358652 (konical Quick-Seal polyallomer) | JS-24.38 |
| 12.5 | 16 x 95 | 0.625 x 3.75 | 361708 (konical thickwall polyallomer) | JS-24.15 |
| 23.0 | 25 x 76 | 1 x 1.5 | 358654 (konical Quick-Seal polyallomer) | JS-24.38 |
| 25.0 | 25 x 76 | 1.0 x 3.0 | 358125 (konical polyallomer) | JS-24.38 |
| 30.0 | 25 x 89 | 1.0 x 3.5 | 358126 (konical polyallomer) | JS-24.38 |
| 230.0 | 62 x 141 | 2.5 x 5.25 | 356987 (polycarbonate bottle with screw cap) | JA-14, JS-7.5, JS-5.2, JS-4.3, JS-4.2, JS-4.2A, JS-4.0, JS-3.0 |
| 230.0 | 62 x 141 | 2.5 x 5.5 | 356989 (polypropylene bottle with screw cap) | JA-14, JS-7.5, JS-5.2, JS-4.3, JS-4.2, JS-4.2A, JS-4.0, JS-3.0 |
| Stainless Steel Tubes | | | | |
| 10.0 | 16 x 76 | 0.6 x 3 | 301108 | JA-21, JA-20.1, JS-4.3, JS-4.2, JS-4.2A, JS-3.0 |

Tubes and Bottles

| Nominal Filling Capacity (mL) | Nominal Size (mm) | Inches | Part No. | Rotors |
|---|-------------------|--------------|------------------------|--|
| Bio-Vial Tubes | | | | |
| 4.0 | 14 x 55 | .5625 x 2.25 | 566353 - Polypropylene | JLA-16.250, JA-14, JLA-10.500, JA-10, JS-7.5, JS-5.2, JS-4.2, JS-4.2A, JS-4.0, JS-3.0 |
| Bottles Only | | | | |
| 1000.0 | 95 x 191 | 3.75 x 7.5 | 366751 - Polycarbonate | JLA-9.1000, JLA-8.1000 |
| 1000.0 | 95 x 191 | 3.75 x 7.5 | 366752 - Polypropylene | JLA-9.1000, JLA-8.1000 |
| Bottles with Caps | | | | |
| 70.0 | 38 x 102 | 1.5 x 4.0 | 355655 - Polycarbonate | JS-5.2, JS-4.2, JS-4.2A, JS-4.0, JS-3.0 |
| 500.0 | 69 x 160 | 2.75 x 6.5 | 355649 - Polycarbonate | JS-5.2, JS-4.2, JS-4.2A, JS-4.0, JS-3.0 |
| 500.0 | 69 x 160 | 2.75 x 6.5 | 361690 - Polycarbonate | JLA-10.500 |
| 500.0 | 69 x 160 | 2.75 x 6.5 | 361691 - Polypropylene | F10 BCI-6x500y, JLA-10.500 |
| Bottles with Cap Assemblies, Polyallomer | | | | |
| 50.0 | 29 x 104 | 1.25 x 4 | 357001 | JA-30.50, JA-20, JA-17, JLA-16.250, JA-14, JA-10.500, JA-10, JS-5.2, JS-4.3, JS-4.2, JS-4.2A, JS-4.0, JS-3.0, F14 BCI-6x250y, F14 BCI-14x50cy |
| 50.0 | 29 x 104 | 1.25 x 4 | 361694 | JA-25.50, JA-17, JA-14 |
| Bottles with Cap Assemblies, Polycarbonate | | | | |
| 50.0 | 29 x 104 | 1.25 x 4.25 | 355600 | JS-7.5 |
| 50.0 | 29 x 104 | 1.25 x 4.25 | 361693 | JA-25.50, JA-17 |
| 50.0 | 29 x 104 | 1.25 x 4.25 | 357000 | JA-30.50, JA-20, JA-17, JLA-16.250, JA-14, JA-10.500, JA-10, JS-5.2, JS-4.3, JS-4.2, JS-4.2A, JS-4.0, JS-3.0, F14 BCI-6x250y, F14 BCI-14x50cy |
| 70.0 | 38 x 102 | 1.5 x 4.0 | 355620 | JA-18, JS-5.2, JS-4.2, JS-4.1A, JS-4.0, JS-3.0 |
| 250.0 | 62 x 122 | 2.5 x 4.75 | 358275 (wide mouth) | JS-4.3, JS-5.2, JS-4.2, JS-4.2A, JS-4.0, JS-3.0, F14 BCI-6x250y |
| 500.0 | 69 x 160 | 2.75 x 6.5 | 355605 (wide mouth) | JA-10, JS-5.2, JS-4.0 |
| Bottles with Cap Assemblies, Polypropylene | | | | |
| 250.0 | 62 x 120 | 2.5 x 4.75 | 358326 (wide mouth) | JS-5.2, JS-4.3, JS-4.2, JS-4.2A, JS-4.0, JS-3.0, F14 BCI-6x250y |
| 500.0 | 69 x 160 | 2.75 x 6.5 | 355607 | JA-10, JS-5.2, JS-4.3, JS-4.2, JS-4.2A, JS-4.0, JS-3.0 |
| Bottles with Screw-on Caps, Polyallomer | | | | |
| 50.0 | 29 x 104 | 1.25 x 4.0 | 357003 | JA-30.50, JA-25.50, JA-20, JA-18, JA-17, JLA-16.250, JA-14, JLA-10.500, JA-10, JS-13.1, JS-7.5, JS-5.2, JS-4.3, JS-4.2, JS-4.2A, JS-4.0, JS-3.0, F14 BCI-6x250y, F14 BCI-14x50cy |
| Bottles with Screw-on Caps, Polycarbonate | | | | |
| 10.0 | 16 x 80 | 0.6 x 3.2 | 355672 | JA-30.50, JA-25.50, JA-21, JA-20.1, JA-20, JA-17, JS-13.1, JS-5.2, JS-4.2, JS-4.2A, JS-4.0, JS-3.0 |
| 10.4 | 16 x 76 | 0.6 x 3.0 | 355603 | JS-7.5 |
| 50.0 | 29 x 104 | 1.125 x 4.0 | 357002 | JA-30.50, JA-25.50, JA-20, JA-18, JA-17, JLA-16.250, JA-14, JLA-10.500, JA-10, JS-13.1, JS-7.5, JS-5.2, JS-4.3, JS-4.0, F14 BCI-6x250y, F14 BCI-14x50cy |
| 230.0 | 62 x 141 | 2.5 x 5.25 | 356987 (conical) | JA-14, JS-7.5, JS-5.2, JS-4.3, JS-4.2, JS-4.2A, JS-4.0, JS-3.0, F14 BCI-6x250y |
| 250.0 | 62 x 120 | 2.5 x 4.75 | 356013 (wide mouth) | JLA-16.250, JA-14, JLA-10.500, JA-10, JS-7.5, JS-5.2, JS-4.3, JS-4.2, JS-4.2A, JS-4.0, JS-3.0, F14 BCI-6x250y |
| 250.0 | 62 x 136 | 2.5 x 5.5 | 355673 | JS-7.5, JS-5.2, JS-4.3, JS-4.2, JS-4.2A, JS-4.0, JS-3.0 |
| 500.0 | 69 x 160 | 2.75 x 6.5 | 355664 | JA-10, JS-5.2, JS-4.2, JS-4.2A, JS-4.0, JS-3.0 |
| 750.0 | 96 x 130 | 3.75 x 5.25 | 358299 | JS-4.3, JS-4.2, JS-4.2A, JS-3.0 |
| 1000.0 | 97 x 167 | 3.75 x 6.75 | 355675 | JS-5.2, JS-4.2, JS-4.2A, JS-4.0, JS-3.0 |
| Bottles with Screw-on Caps, Polypropylene | | | | |
| 100.0 | 38 x 102 | 1.5 x 4.0 | 355624 | JA-18, JS-5.2, JS-4.3, JS-4.2, JS-4.2A, JS-4.0, JS-3.0 |
| 230.0 | 62 x 141 | 2.5 x 5.5 | 356989 | JA-14, JS-7.5, JS-5.2, JS-4.3, JS-4.2, JS-4.2A, JS-4.0, JS-3.0, F14 BCI-6x250y |
| 250.0 | 62 x 120 | 2.5 x 4.75 | 356011 (wide mouth) | JLA-16.250, JA-14, JLA-10.500, JA-10, JS-7.5, JS-5.2, JS-4.3, JS-4.2, JS-4.2A, JS-4.0, JS-3.0, F14 BCI-6x250y |
| 500.0 | 69 x 159 | 2.75 x 6.5 | 355665 | JA-10, JS-5.2, JS-4.3, JS-4.2, JS-4.2A, JS-4.0, JS-3.0 |
| 750.0 | 96 x 130 | 3.75 x 5.25 | 356855 | JS-5.2, JS-4.3, JS-4.2, JS-4.2A, JS-4.0, JS-3.0 |
| 1000.0 | 97 x 167 | 4.0 x 6.75 | 355676 | JS-5.2, JS-4.2, JS-4.2A, JS-4.0, JS-3.0 |

Tools and Supplies

Tools and Supplies

Tools for Quick-Seal® Tubes

338765 Removal Tool, for Floating Spacers (except when used in Swinging Bucket Rotors)



354468 Removal Tool, for konical™ Tube Adapters used in Swinging Bucket Rotors



342415 Funnel



348120 Seal Formers (round-topped) for use with Tube Topper

345395 Ultra-Clear™ Tube Sealing Oil, 7.5 mL bottle

361668 Removal Tool for Tubes and Spacers (and Floating Spacers in Swinging Bucket Rotors)



Quick-Seal® Tube Racks

For Cordless Tube Topper

These autoclavable racks accommodate Quick-Seal Tubes for use with the Cordless Tube Topper.

348123 Tube Rack (Green), for 5/8-in. (16 mm) diameter Tubes

348124 Tube Rack (Blue), for 1-in. (25 mm) diameter Tubes

348125 Tube Rack (Black), for 1 1/2 -in. (38 mm) diameter Tubes

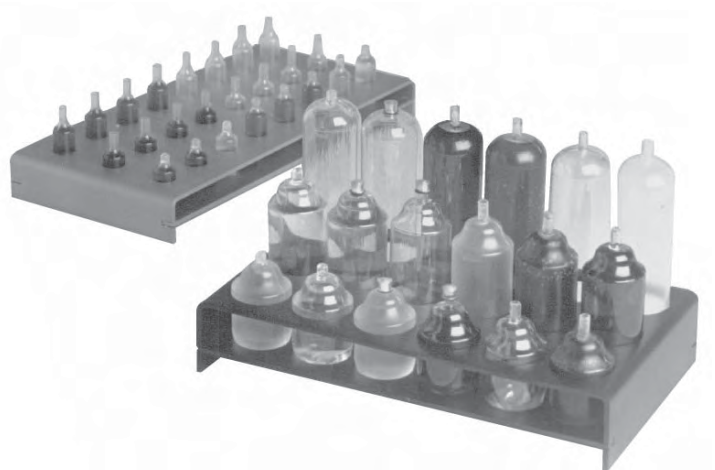

Cordless Tube Topper

- 358312 Tube Topper Kit, 60 Hz (for U.S. and Japan)
- 358313 Tube Topper Kit, 50 Hz (for Europe)
- 358314 Tube Topper Kit, 50 Hz (for Great Britain)
- 358315 Tube Topper Kit, 50 Hz (for Australia)
- 367803 Tube Topper Kit, 60 Hz (for Canada)

Each Kit Contains:

- 1 each 348117 Heatsink, 2 each 348643 Seal Guide,
- 8 each 348120 Seal Former (domed top), 1 each Tube Topper and Charging Unit, 1 each 361668 Tube Extractor.

Replacement Parts

- 348117 Heat Sink
- 348120 Seal Former (domed top) for Tube Topper
- 357442 Flat-top Seal Former for Tube Sealer
- 348643 Seal Guide
- 889676 Plastic Box for holding Accessories
- 342415 Funnels (two)
- 338765 Removal Tool for Plastic Spacers and Floating Spacers
- 358317 Tip
- 927937 Battery
- 961601 Lamp (screw-type socket)
- 974874 Lamp (bayonet-type socket)



2

Rotor Cleaning Kit



- 339558** Rotor Cleaning Kit. Contains two 946-mL bottles of Solution 555™ Rotor Cleaning Concentrate, 339379 Rotor Cleaning Brush, and 339380 Rotor Cleaning Brush

Replacement Parts/Supplies

- 339555** Solution 555 Rotor Cleaning Concentrate (min. order two Bottles)
- 339379** Rotor Cleaning Brush, 5/8-in. (16 mm) and 1-in. (25.4 mm), for Rotor Cavity diameters from 7/16-in. (11 mm) to 1-in. (25.4 mm) (min. order three Brushes)
- 339380** Rotor Cleaning Brush, 1 1/4-in. (32 mm) and 1 1/2-in. (38 mm), for Rotor Cavity diameters from 1-in. (25.4 mm) to 1 1/2-in. (38 mm) (min. order three Brushes)

Reference

Guide to Centrifuge Selection

Centrifugation is a basic separation technique that is utilized at multiple stages in the study of sample components. Flexible rotor and adapter systems for each Beckman Coulter centrifuge allow them to be used across multiple application areas. To help you select the most appropriate centrifuge for your work, the following charts provide brief descriptions of the kinds of separations typically achieved using various centrifuges. These charts list frequent separation requirements for each sample type, and identify the centrifuges that are typically used to meet those requirements.

In addition to the separation and isolation of sample particles, centrifugation is increasingly being used as an analytical technique for the study of macromolecular interactions and the determination of molecular weights. Instruments for these applications are also listed below.

Quick-Reference Guide to Centrifuge Selection

| Materials to Be Isolated | Specific Application | Centrifuges Typically Used | | |
|------------------------------|---|----------------------------|-------|-------------|
| | | J2 and Avanti® J | J6-MI | Avanti J-HC |
| Proteins | Ammonium sulfate precipitates Centrifugal filtration | ● ● | ● | ● |
| Subcellular Fractions | | | | |
| Chromatin/Nucleosomes | Sucrose gradient isolation | ● | | ● |
| Microsomes | Pelleting | ● | | |
| | Sucrose gradient isolation | ● | | |
| | Microsomal membrane fractionation | ● | | |
| Mitochondria | Pelleting | ● | | ● |
| | Sucrose gradient isolation | ● | | |
| Nuclei | Pelleting | ● | ● | ● |
| Membranes | Pelleting | ● | | ● |
| | Sucrose/Percoll gradient fractionation | ● | | ● |
| | Binding studies | ● | | ● |
| Ribosomes/Polysomes | Pelleting | ● | | |
| | Size fractionation in sucrose gradients | ● | | |
| Cytosol | Clarification | ● | | ● |

Reference

Quick-Reference Guide to Centrifuge Selection (cont'd)

| Materials to Be Isolated | Specific Application | Centrifuges Typically Used | | |
|-----------------------------------|---|----------------------------|-------|-------------|
| | | J2 and Avanti® J | J6-MI | Avanti J-HC |
| Preparative Centrifugation | | | | |
| Lysates/Homogenates | Clearing debris and large particles | • | • | • |
| Nucleic Acids | | | | |
| DNA | Alcohol precipitation | • | | |
| | Phenol/CHCl ₃ extraction | • | | |
| | Size fractionation in sucrose gradients | • | | |
| | Minipreps in 96-well plates | | • | • |
| | Spin columns | • | • | • |
| RNA | Phenol/CHCl ₃ extraction | • | | |
| | Alcohol precipitation | • | | |
| | Lithium precipitation | • | | |
| Cells | | | | |
| Cells | Isolation of mononuclear cells on Ficoll-Hypaque | | • | • |
| | Pelleting bacteria | • | • | • |
| | Pelleting mammalian cells | | • | • |
| | Elutriation of viable cells | • | • | • |
| | Other density gradient separations | • | • | • |
| Viruses | | | | |
| Viruses | Pelleting | • | | |
| | PEG precipitates | • | | |
| | Density gradient isolations | • | | |
| Blood | | | | |
| Blood | Plasma preparation | | • | |
| | Blood-cell products | | • | |

Reference

Useful Formulas

***k* Factor**

To determine *k* factor

$$k = \frac{\ln(r_{\max}/r_{\min})}{\omega^2} \times \frac{10^{-13}}{3600} \quad \text{OR} \quad k = \frac{2.53 \times 10^5 \ln(r_{\max}/r_{\min})}{(\text{RPM}/1000)^2}$$

To determine pelleting time (*t*)

$$t = \frac{k}{s} \quad \text{where } s = \text{sedimentation coefficient in Svedbergs}$$

To relate pelleting time between rotors

$$\frac{k_1}{t_1} = \frac{k_2}{t_2}$$

To adjust *k* factor for runs less than maximum rotor speed

$$k_{\text{adj}} = k \left(\frac{\text{maximum rated speed of rotor}}{\text{actual run speed}} \right)^2$$

To relate relative centrifugal force (RCF) to speed (RPM):

$$\text{RCF}_{\max} = 1.12 r_{\max} \left(\frac{\text{RPM}}{1000} \right)^2 \quad \text{OR} \quad \text{RPM} = 10^3 \sqrt{\frac{\text{RCF}}{1.12 r_{\max}}}$$

To relate the sedimentation coefficient (*s*) to rotational speed:

$$s = \frac{dr}{dt} \times \frac{1}{\omega^2 r}$$

Svedberg unit (*S*) equivalent:

$$S = 10^{-13} \text{ seconds}$$

Reduced run speed for dense solutions:

$$\text{reduced run speed} = \text{max rated speed of rotor} \times \sqrt{\frac{A}{B}}$$

where A = max. permissible density of rotor tube contents, and
B = actual density of the tubes to be centrifuged

Support Services

Beckman Coulter simplifies and automates your laboratory processes. From consultation in choosing products and services, through installation, training and support, we are committed to making your laboratory the most efficient and cost-effective operation it can be. Advancements in communications technology, system diagnostics and our field network makes it even easier for you to get the system support you need. With a variety of new programs in place, Beckman Coulter can bring your lab the most streamlined, intelligent and customer-focused service in the industry.

Whether your system service is provided on-call, on-line or on-site, you'll get the world class customer support you expect from a technology leader.

3

Support Services

ON-CALL: System Experts at Your Fingertips

Our customer call centers provide the first line of support in resolving your technical issues. As soon as you provide your unique System Identification Number, your call will be routed automatically to system and scientific specialists. The specialist who receives your call will have immediate access to your system's complete service history and your experience with the system. These qualified specialists can then immediately identify, isolate and resolve most technical issues – preventing simple problems from becoming more complicated. If the problem can't be resolved, our computer system will forward the information to the Beckman Coulter dispatch group for immediate assignment to a field system engineer.

ON-LINE: Product Support on Your Schedule

Our web-based information resource provides you with 24-hour-a-day access to a wide array of helpful information.

- FAQs, troubleshooting, MSDSs
- How to place service requests
- Part numbers
- Catalogs, product selection guides, rotor calculations and selection
- Customer Technical Support contact information

ON-SITE: Factory Trained Field System Engineers

When the need arises for on-site support, one of Beckman Coulter's professional field system engineers is always available to service your system on-site. Through our global network of system and process experts, a Beckman Coulter

field system engineer is available to provide hands-on support and keep your lab processes running smoothly. To meet the various needs of the scientific laboratory, Beckman Coulter offers a wide range of on-site technical solutions for your lab.

- Support agreement options
- Regulatory compliance programs (installation and operational qualification)
- Centrifuge rotor inspection programs
- Training
- Technical services on a time and material basis

Regardless of the support agreement selected, you are assured that Beckman Coulter provides only the finest quality support and is certified under ISO 9001 quality standards.

ON-FILE: Your System Identification Number

Your instrument's System Identification Number is your key to Beckman Coulter service and support. Use it to identify yourself whenever you call for technical assistance. Don't worry about a model or serial number – all the information we need is contained in the System Identification Number. If you have several instruments, each one will have a unique number. Please keep your System Identification Number accessible and readily available. It's just one more way we strive to give you the best customer support possible. If you do not already have a System Identification Number, contact the Beckman Coulter Customer Technical Support department.

CUSTOMER TECHNICAL SUPPORT

U.S.: (800) 551-1150

Canada: (800) 387-6799

www.beckmancoulter.com/biosupport